

Basiselement / Base element

Element	TN / Part No.	L (mm)	H (mm)
BE 20-010	5150012	10	10
BE 20-020	5150013	20	10
BE 20-030	5150014	30	10
BE 20-050	5150030	50	20

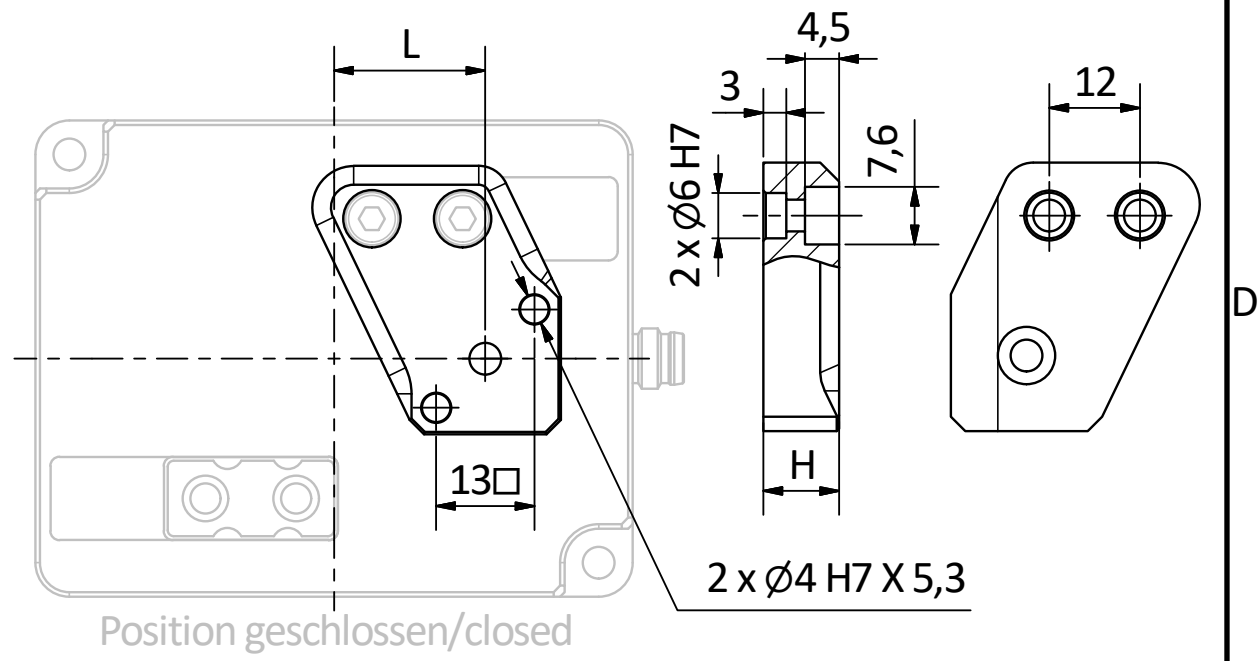

Winkelement / Angle connector

Element	TN / Part No.
AC 20-025	5150018

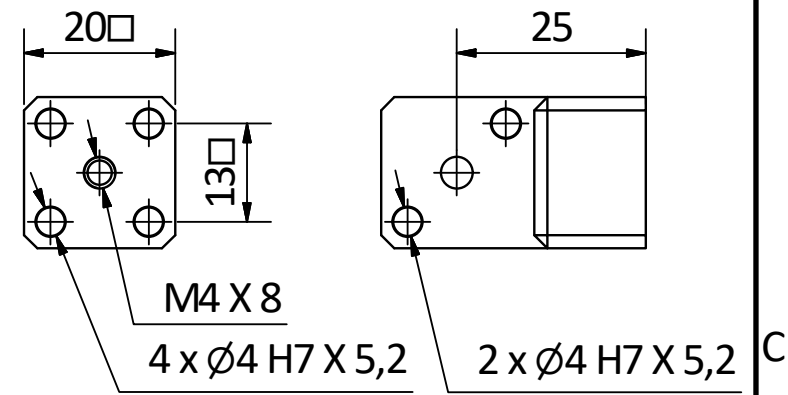
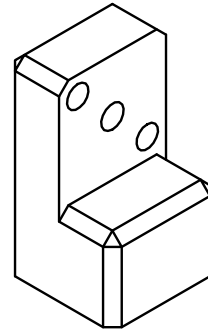

Fingerelement / Finger Element

Element	TN / Part No.	L (mm)
FE 20-030	5150015	30
FE 20-050	5150016	50
FE 20-100	5150017	100

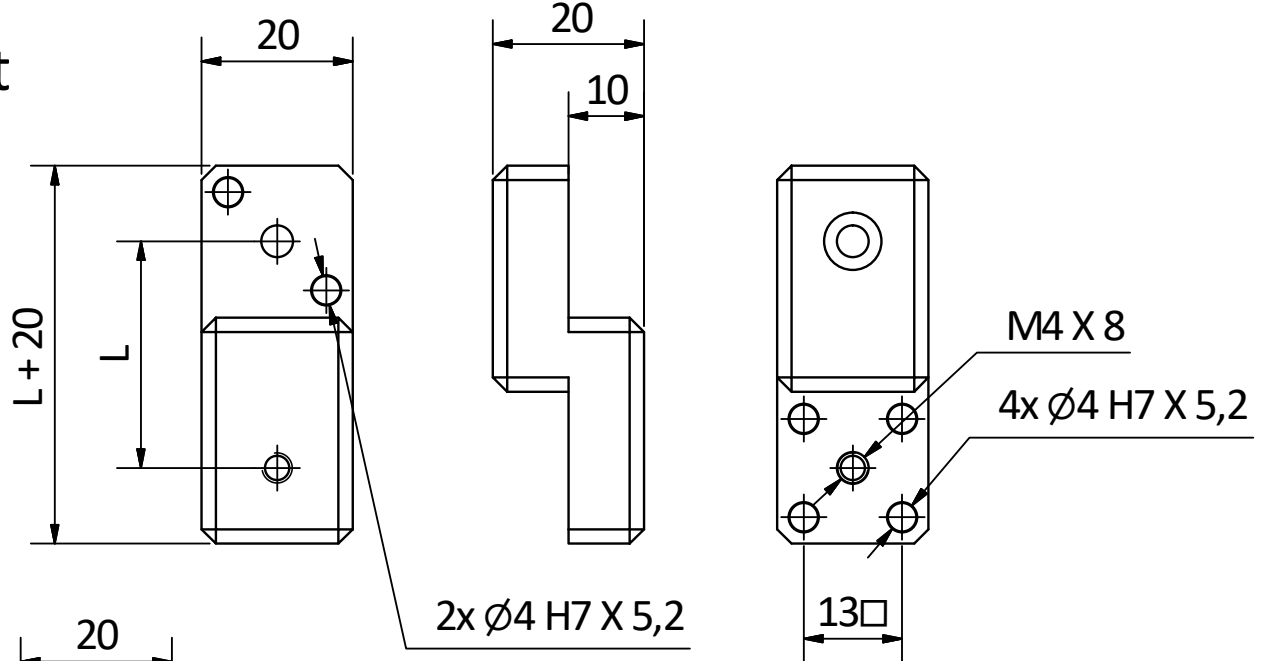

T-Element

Element	TN / Part No.	L (mm)
TE 20-060	5150019	60
TE 20-080	5150020	80
TE 20-100	5150021	100

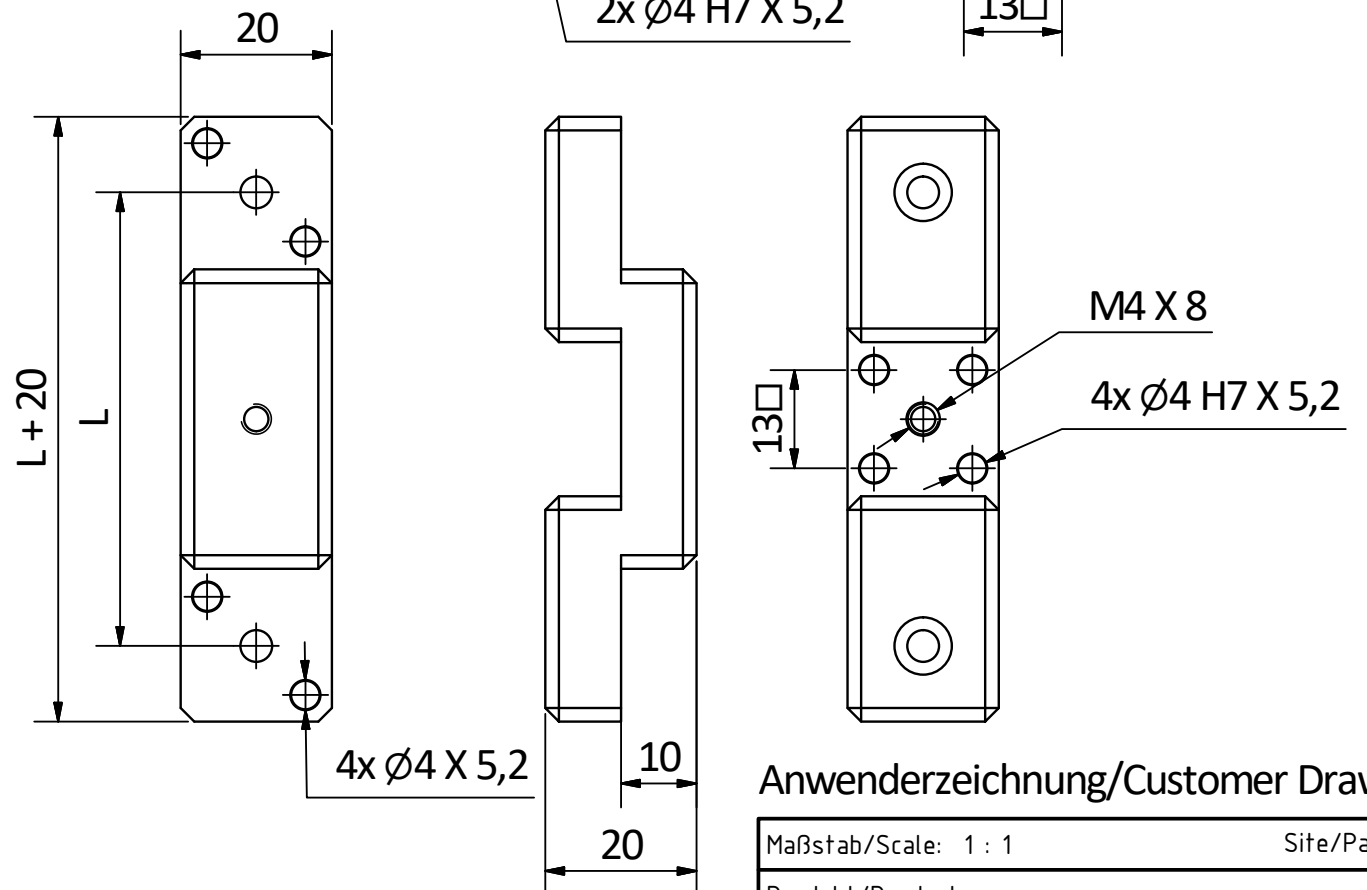

Anwenderzeichnung/Customer Drawing

Maßstab/Scale: 1 : 1

Site/Page: 1

Produkt/Product:

Fingerkit System 20

 WEISS ROBOTICS

www.weiss-robotics.com

Copyright Weiss Robotics GmbH & Co. KG, all rights reserved

Distanzplatte / Distance plate

Element	TN / Part No.
DP 20-005	5150022

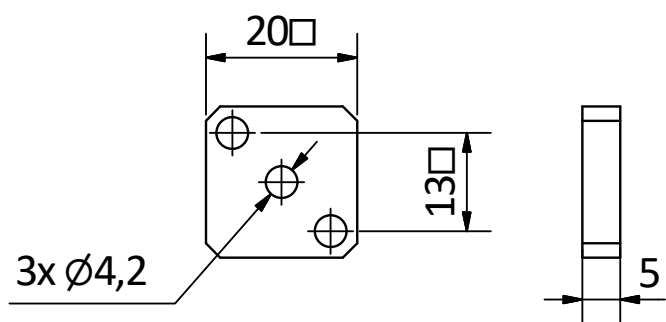

Greifeinsatz / Grip insert

Element	TN / Part No.
FT 20-CR	5150027
FT 20-UNI	5150028

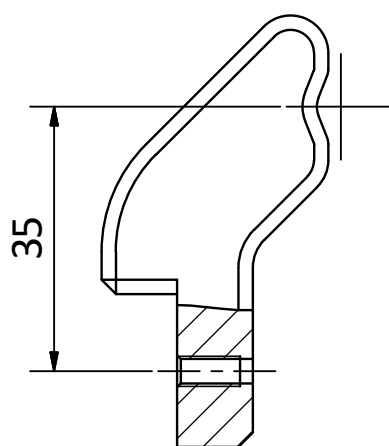
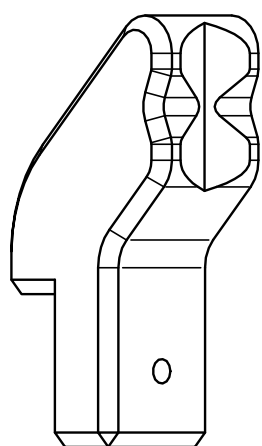

FT 20-CR

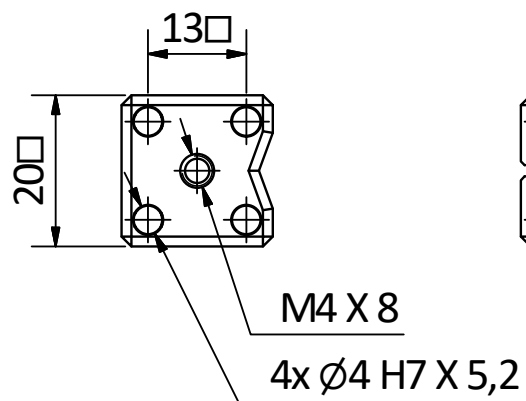
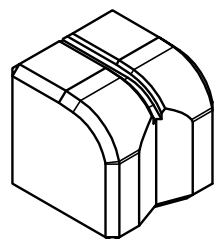
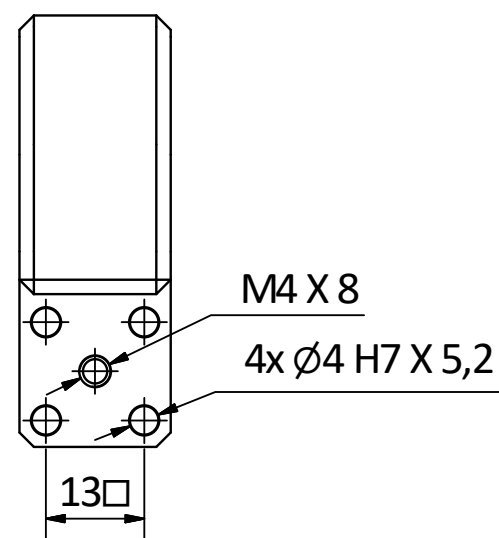

FT 20-UNI

Anwenderzeichnung/Customer Drawing

Maßstab/Scale: 1 : 1

Site/Page: 2

Produkt/Product:

Fingerkit System 20

