

Mounting and Operating Manual

CRG Series - Electrical Gripping Modules with IO-Link

September 2025



www.weiss-robotics.com

Contents

1	Introduction	4
1.1	Product Specification	4
1.2	Applicable Documents	4
1.3	Target Audience	5
1.4	Notation and Symbols	5
2	Basic Safety Notes.....	5
2.1	Intended Use.....	5
2.2	Environmental and Operating Conditions.....	6
2.3	Product Safety.....	6
2.3.1	Protective Equipment.....	6
2.3.2	Constructional Changes, Attachments, or Modifications.....	6
2.3.3	Special Standards.....	6
2.4	Personnel Qualification	7
2.5	Safety Considerations	7
2.6	Notes on Particular Risks	7
3	Warranty	7
4	Scope of Delivery and Accessories.....	8
5	Technical Data	9
5.1	Nominal Mechanical Data.....	9
5.1.1	Max. Permitted Finger Length.....	9
5.1.2	Gripping Force and Finger Speed	10
5.1.3	Cycle Times	11
5.1.4	Max. Permitted Finger Load	12
5.2	Nominal Electrical Data.....	13
5.2.1	Electrical Interface.....	13
5.3	Name Plate	14
6	Installation and Commissioning	14
6.1	Installation.....	14
7	Functional Principle of the Gripping Module.....	17
7.1	Typical Application	18
7.2	Gripping force retention	18

7.3	State visualization by luminous ring	19
7.4	Non-volatile Memory	19
8	Interface Description IO-Link.....	20
8.1	Cyclic Process Data	20
8.1.1	Output Data (IO-Link Master to Gripping Module)	20
8.1.2	Input Data (Gripping Module to IO-Link Master)	22
8.2	Acyclic Process Parameters and System Commands.....	24
8.2.1	Remanent Storage of Acyclic Process Parameters	24
8.2.2	Standardized Acyclic Process Parameters	25
8.2.3	Device-specific Acyclic Process Parameters	26
8.2.3.1	Motion Parameters.....	26
8.2.3.2	Grip Parameters.....	27
8.2.3.3	Virtual Position Switches.....	29
8.2.3.4	Visualization with luminous ring	30
8.2.3.5	Diagnosis Parameters	33
8.2.3.6	Protocol Memory.....	35
8.2.3.7	Extended Configuration Parameters.....	36
8.2.4	System Commands	37
8.3	System Events (IO-Link Events)	37
9	Control of the Gripping Module	38
9.1	Gripping Commands	39
9.2	Position Sensors	39
9.3	Reference Run	40
9.4	Virtual Position Switches	40
9.5	Gripping State	41
9.6	Parameterizable Grips	42
9.6.1	Gripping Direction	43
9.7	Grip Part	44
9.7.1	Gripping with high gripping force or over a long period of time	44
9.8	Release Part	45
9.9	Troubleshooting	45
9.10	Activating and Deactivating the Module (Setup Mode)	47
9.11	Gripping force retention	47
9.12	Visualization with illuminated ring	47
9.13	Design of the Gripping Process.....	48

9.13.1	Application Example External Gripping	49
9.13.2	Application Example Internal Gripping.....	50
9.14	Function Block for Siemens TIA Portal	51
10	Maintenance and Cleaning.....	51
10.1	Needs-based Maintenance	52
10.2	Resetting the Maintenance Interval Count	53
11	Troubleshooting	53
11.1	The Base Jaws Do Not Move	53
11.2	Gripping Module Stops Abruptly or Does Not Complete the Entire Stroke.....	53
11.3	No Communication with the Gripping Module.....	54
11.4	The Gripping Module Reports an Error	54
12	APPENDIX A - Device-specific Process Parameters	56
13	APPENDIX B - Configuration Example	60
13.1	Preparation	60
13.2	Configuration of the IO-Link Master	60
13.3	Configuration of the Gripping Module.....	63
13.4	Parameterization of the Gripping Module	64
13.5	Diagnosis.....	65
14	EC Declaration of Incorporation	66

1 Introduction

This manual is an integral part of the gripping module and describes the safe and proper handling during all operational phases. It is valid solely for gripping modules of the CRG series and contains important information on assembly, commissioning, maintenance, and service.

1.1 Product Specification

The gripping modules of the CRG series are ultracompact servo-electrical gripping modules with innovative gripping force regulation and integrated IO-Link technology. Figure 1 shows the connectors and components of an CRG gripping module. The gripping module can be configured via the configuration software of the IO-Link master or via the DC-IOLINK device configurator, which is available separately.

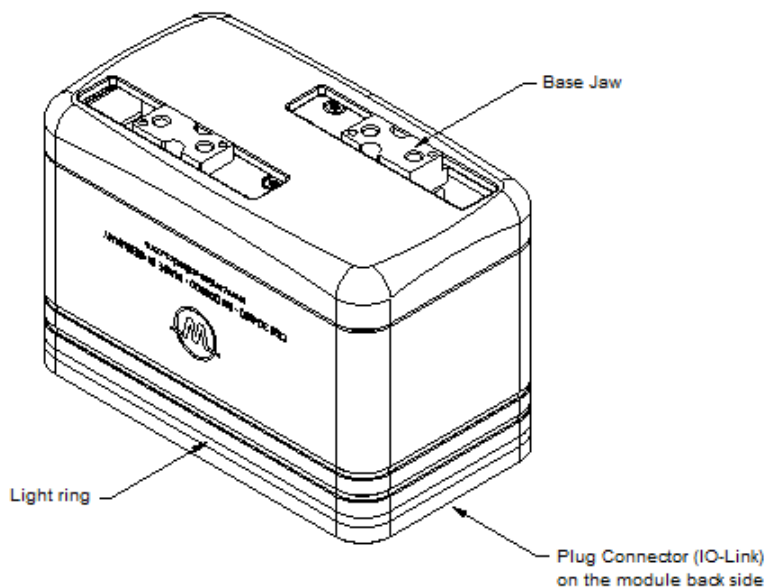

Figure 1: Components and connectors of the gripping module

1.2 Applicable Documents

For more detailed information on operating this module, please consult the following documents, which are available for download on our website at <https://www.weiss-robotics.com/crg/>:

- Technical drawing
- 3D model (STEP)
- IO-Link device description file (IODD)
- Function block for Siemens TIA portal

Please find additional information about the warranty in our general terms and conditions, available online at <https://www.weiss-robotics.com/gtc/>.

1.3 Target Audience

These instructions are targeted at plant manufacturers and operators, who should make this and other documents permanently available for the personnel and should also ask the personnel to read and observe particularly the safety instructions and warnings.

In addition, this manual is targeted at professionals and technicians, who should read this manual and should particularly observe the safety and warning notes at all times.

1.4 Notation and Symbols

For better clarity, the following symbols are used in this manual:



Functional or safety-related information. Failure to comply may jeopardize the safety of personnel and equipment, damage the device, or impair the functionality of the device.



Additional information for a better understanding of the facts described.



Reference to further information.

2 Basic Safety Notes

2.1 Intended Use

The module was designed to grip and temporarily and securely hold work pieces and objects. The module is intended for installation in a machine/system. The requirements of the applicable guidelines as well as the mounting and operating notes in this manual must be observed and complied with. The gripping module may only be used in the context of its defined application parameters and only in industrial applications.

Any other use or use exceeding the intended use is deemed improper, e.g. when the gripping module is used as a pressing, cutting, lifting, or punching tool, or when it is used as a clamping device or guide for other tools. The manufacturer is not liable for any damage resulting from such use.

2.2 Environmental and Operating Conditions

The module may only be used within its defined application parameters. It must be ensured that the module and the fingers are sufficiently dimensioned for the intended application, and that the environment is clean and the ambient temperature meets the requirements specified in the data sheet. Please observe the maintenance instructions (see chapter 10). Furthermore, it must be ensured that the environment is free from splash water and vapors as well as from abrasion or process dust. Excepted are modules that are specifically designed for dirty environments.

2.3 Product Safety

The gripping module uses state-of-the-art technology and complies with the recognized safety rules and regulations at the time of delivery. However, dangers may arise from the module if e.g.:

- the gripping module is not used in accordance with its intended purpose.
- the gripping module is installed, modified, or maintained improperly.
- operators do not comply with the EC Machinery Directive, the VDE guidelines, the local safety and accident prevention regulations, or with the safety and installation notes.

2.3.1 Protective Equipment



To provide protective equipment according to the EC Machinery Directive, a risk assessment in accordance with applicable standard is necessary.

2.3.2 Constructional Changes, Attachments, or Modifications

Additional bore holes, threads, or attachments not offered by Weiss Robotics as accessories may be mounted only after obtaining the written approval of Weiss Robotics.

2.3.3 Special Standards

The following standards are met:

- RFI voltage, interference field strength and emission according to EN 61000-6-3
- Fast transients on signal and data lines according to EN 61000-4-4
- HF power input on signal and data lines according to EN 61000-4-6
- HF radiation according to EN 61000-4-3
- Emissions according to EN 61000-6-4 Class A
- Power frequency magnetic field according to EN 61000-4-8
- Static electrical discharge according to EN 61000-4-2

- IO-Link communication standard according to IEC 61131-9
- Robots and robotic devices – Collaborative robot according to ISO/TS 15066:2016



2.4 Personnel Qualification

The assembly, initial commissioning, maintenance, and repair of the module may be performed only by trained specialist personnel.



Every person commissioned by the operator to work on the module must have read and understood the complete mounting and operating manual, especially chapter 2 “Basic safety notes”. This also applies to personnel that is only employed occasionally, e.g. maintenance personnel.

2.5 Safety Considerations

Even though the CRG series are for the collaborative operation, the safety and accident prevention regulations valid at the operation site must be observed.

-  **Do not move parts by hand when the module is connected to the power supply.**
-  **Do not reach into the open mechanical parts and avoid reaching the movement area of the gripping module.**
-  **Disconnect the power supply of the module before any installation, modification, maintenance, or adjustment work.**

2.6 Notes on Particular Risks

-  **Risk of injury from objects falling and being ejected. Take appropriate safety measures to prevent the falling or ejection of objects, e.g. processed parts, tools, shavings, fragments, waste.**
-  **Risk of injury due to unexpected movements of the machine.**

3 Warranty

The warranty is valid for 24 months from the delivery date to the production facility if the module is operated in one-shift operation mode and according to the specified maintenance and lubricating intervals, or up to 10 million gripping cycles, respectively. Parts touching the work piece and wear parts are not part of the warranty. Please also note the general terms and conditions.

The gripping module is considered defective if its basic function “gripping” cannot be performed anymore.

4 Scope of Delivery and Accessories

The scope of delivery comprises:

- Gripping module CRG in the version ordered
- Accessory kit (centering sleeves or dowel pins matching the module's diameter)
- Quick guide CRG series

Item	CRG 30-050	CRG 200-085
Gripping module	5010016	5010017
Accessory kit	5020051	5020054
Quick guide	5080033	5080033

Table 1: Part numbers scope of delivery

For the gripping module, the following accessories are available separately:

- Flange adapter for robots with ISO standard flange
- Device configurator for gripping modules of the Integration Line, DC-IOLINK, part number 5020009
- Power supply cables



Please order accessories separately.

More accessories can be found on our website at <https://www.weiss-robotics.com>.

4.1 Complete solution for Universal Robots

For Universal Robots arms, there is a kit comprising gripping module, flange adapter, control interface, cables, and mounting material available.

Item	CRG 30-050	CRG 200-085
GRIPKIT designation	GRIPKIT-CR1	GRIPKIT-CR2
Teilenummer	5100006	5100007

Table 2: Part numbers scope of GRIPKIT



More information can be found on our GRIPKIT website at <https://www.weiss-robotics.com/grip-kit>

5 Technical Data

5.1 Nominal Mechanical Data

 Exceeding the specified nominal data may damage the module. If in doubt, please discuss your application with our technical sales department.

Mechanical operating data	Unit	CRG 30-050	CRG 200-085
Total stroke	mm	50	85
Nominal gripping force (100%)	N	30	200
Recommended minimum gripping force (50%)	N	15	100
Max. relative finger speed	mm/s	180	140
Min. relative finger speed	mm/s	10	10
Recommended workpiece weight	g	150	1000
Max. permitted finger length (L) ¹	mm	70	100
Max. permitted mass per finger	g	130	300
Protection class	IP	40	
Ambient temperature	°C	5 ... 50	
Air humidity	%	0 ... 90 non-condensing	
Mechanical repeatability	mm	± 0,03	
Resolution of the measuring system	mm	0,01	
Working principle of the measuring system		absolute + relative	
Weight	g	460	1110

Table 3: Nominal mechanical data

5.1.1 Max. Permitted Finger Length

The maximum finger length L corresponds to the distance between the mounting surface of the base jaw and the point where the gripping force is effectively applied, see Figure 2. The maximum values for L can be found in the nominal mechanical data of the respective gripping module. When the maximum finger length is exceeded, it is mandatory to reduce the gripping force. Furthermore, the operating life may be reduced.

¹ At nominal force, see measure "L" in Figure 2

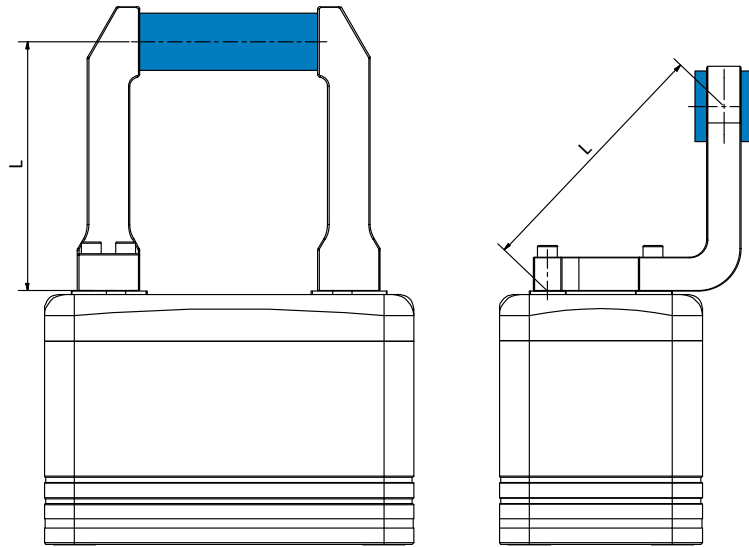

Figure 2: Determination of the finger length "L". Left: straight fingers, right: angled fingers

5.1.2 Gripping Force and Finger Speed

The gripping force can be set as a percentage of the nominal gripping force. The recommended minimum gripping force is 50% of the nominal gripping force.

The gripping module sets the finger speed depending on the parameterized gripping force, see Figure 3. This minimizes the gripping impulse and rebound effects during undamped gripping. The gripping speed can be increased or decreased manually (and thus adjusted to the part that is being gripped) via the central override parameter (gray area; see also chapter 8.2.3.1). To ensure proper movement of the fingers, the minimum possible gripping speed is limited to 10 mm/s.

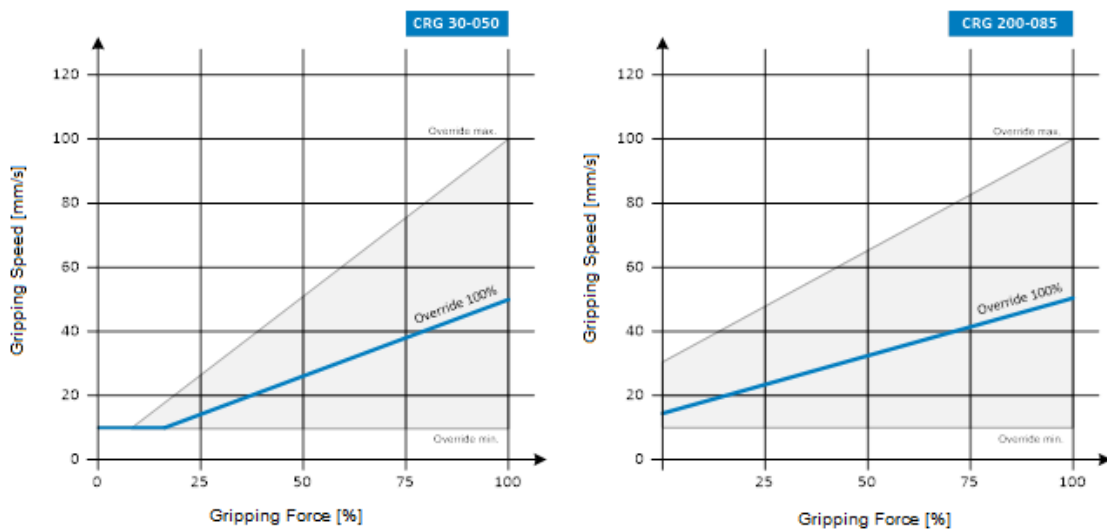

Figure 3: Gripping speed depending on the parameterized gripping force

⚠ Gripping speeds exceeding 100% (override) lead to an increased gripping impulse that can damage the part that is being gripped and the gripping mechanism.

5.1.3 Cycle Times

The following diagrams show the typical progression of gripping time and release time for different gripping force settings.

! The displayed values show the typical time from the processing of the command at the gripping module to the change of the gripping state. The actual time varies depending on the part that is being gripped (firm or elastic), finger weight, gripping height, etc. For an exact assessment of the possible cycle times, tests must be carried out in individual cases.

CRG 30-050

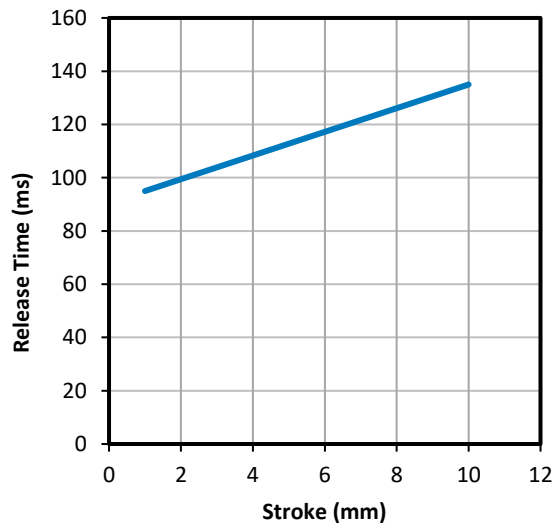
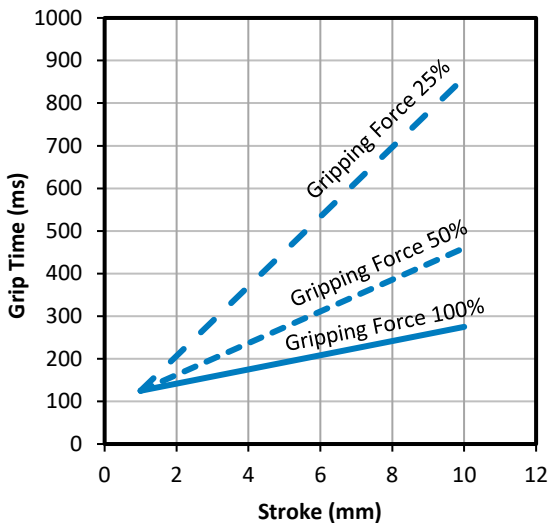

CRG 200-085

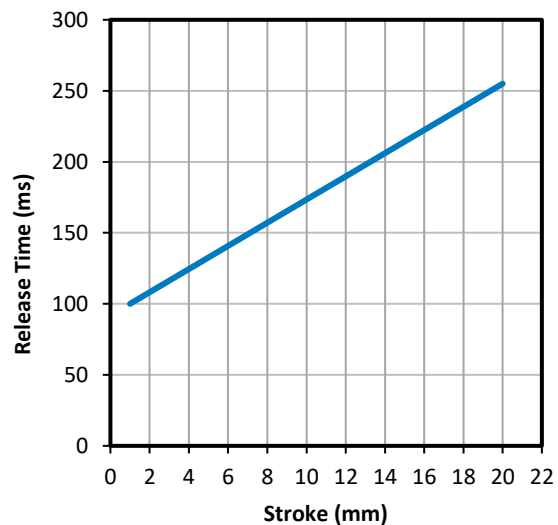
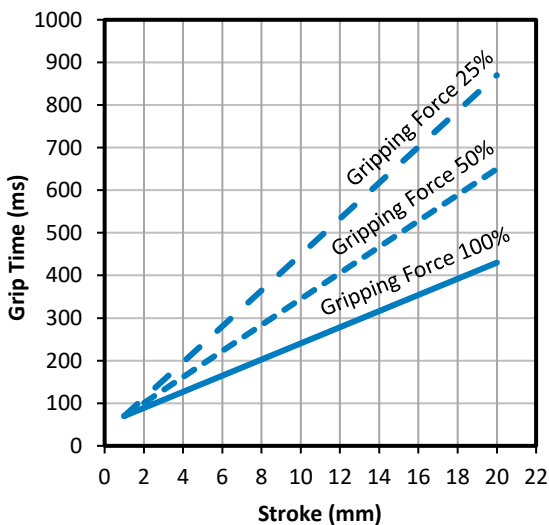

5.1.4 Max. Permitted Finger Load

The following table shows the maximum permitted static loads on the base jaw guide.

Load	Unit	CRG 30-050	CRG 200-085
C_0	N	841	1890
T_x	Nm	2.2	6.9
T_y	Nm	8.0	26.0
T_z	Nm	7.2	23.6

Table 4: Static guide loads

In the case of overlaid forces and torques, the carrying capacity of the guide must be recalculated according to the following equation:

$$\frac{M_x}{T_x} + \frac{M_y}{T_y} + \frac{M_z}{T_z} + \frac{F_z}{C_0} \leq 1.0$$

C_0 and T are the permitted guide loads according to Table 4 and M is the sum of all occurring torques per base jaw (gripping, weight, inertia, and process forces) in the application.

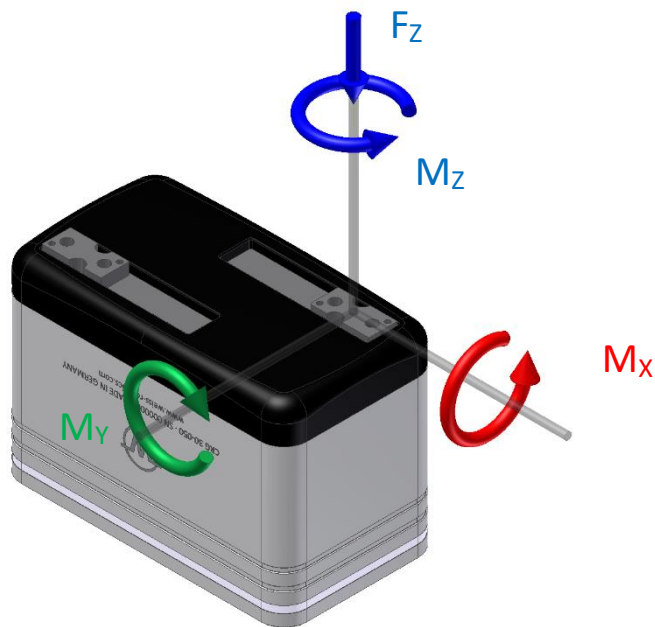



Figure 4: Finger loads

5.2 Nominal Electrical Data

 Exceeding the specified nominal data may damage the module. If in doubt, please discuss your application with our technical sales department.

Electrical operating data	Unit	CRG 30-050	CRG 200-085
Supply voltage	V	18 ... 30	
Typ. current drawn (state IDLE)	mA	140	200
Max. current drawn (holding, gripping force 100%)	mA	240	430
Max. current drawn (moving, peak current)	mA	600	700
<i>C/Q-Pin</i>			
Input voltage range	V	0 ... 30	
Threshold "HIGH"	V	13	
Threshold "LOW"	V	8	
Hysteresis	V	2,2	

Communication	Unit	Value
Standard		IO-Link V1.1
Transmission rate	bit/s	38.400 (COM2)
Min. cycle time	ms	4,0
Max. starting time IO-Link ²	ms	280
Max. starting time operational readiness ³	ms	750

Table 5: Electrical nominal data

5.2.1 Electrical Interface

The gripping module has a four electrical contact. The assignment is shown in Figure 5.

 Depending on the build size, the gripping module may draw more current than the 200 mA specified by the IO-Link 1.1 standard. It is therefore imperative to check whether the IO-Link master can permanently provide the nominal current specified in Table 5.

² Time from supply voltage $\geq 18V$ until communication readiness via IO-Link

³ Time from supply voltage $\geq 18V$ until operation readiness of the gripping module (without referencing)

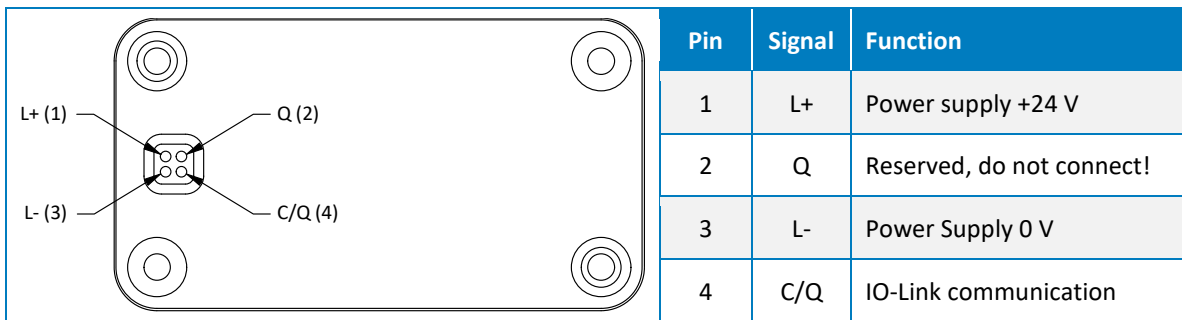

Figure 5: Pin assignment (view on connector)

5.3 Name Plate

The name plate is on the transverse side of the gripping module and contains the serial number, the hardware version, and the exact type designation.

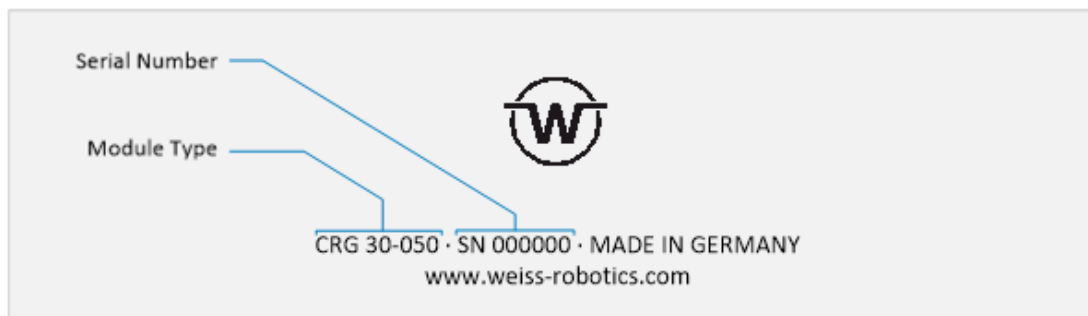

Figure 6: Name Plate

6 Installation and Commissioning

⚠ Risk of injury due to unexpected movements of the machine. Disconnect the module from the power supply during all maintenance work/adjustments and make sure the module is force-free.

6.1 Installation

You can find the dimensions of the threads and centering holes that can be used to mount the module in the technical drawing of the respective build size. The following maximum torques and minimum screw depths must be observed during assembly:

Thread	M3	M4	M6
Casing (aluminum)	0.7 Nm	1.3 Nm	3 Nm
Base jaw (steel)	1.3 Nm	3 Nm	10 Nm
Minimum screw depth	3 mm	4 mm	6 mm

Table 6: Tightening torques for screws (min. strength class 8.8)

The gripping module can be mounted from two sides, see Figure 6. A mounting adapter is available for mounting on a standard ISO flange.

! Maximum allowable unevenness of the mounting surface: 0.02 mm

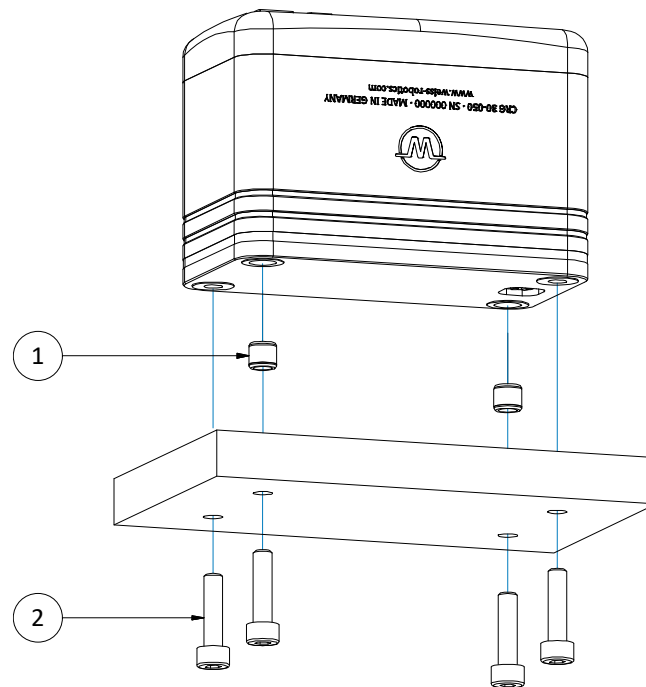

Figure 6: Mounting methods for the gripping module

Figure 7 shows the mounting of the fingers. The centering sleeves and pins (for build size 30) must be used for mounting. They can be found in the accessory kit of the gripping module.

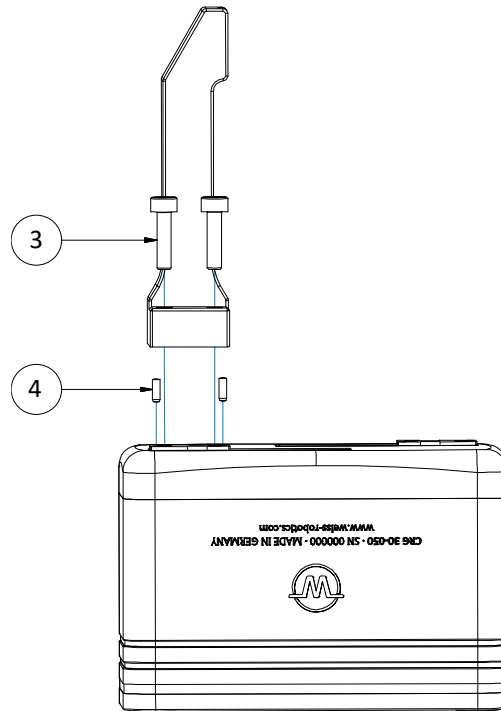

Figure 7: Mounting the fingers

The recommended screws and centering sleeves are listed in Table 7.

Position	CRG 030-050	CRG 200-085
1	2 pieces Centering sleeve 6h6 x 5,5 Weiss Robotics part no. 2090046	2 pieces Centering sleeve 6h6 x 5,5 Weiss Robotics part no. 2090046
2	2 pieces Screw ISO 4762 - M4	2 pieces Screw ISO 4762 - M4
3	2 pieces Screw ISO 4762 – M3	4 pieces Screw ISO 4762 – M3
4	2 pieces Centering pin ISO 8734 - 1.5 m6	2 pieces Centering sleeve 6h6 x 5.5 Weiss Robotics part no.: 2090046

Table 7: Screws and centering sleeves

7 Functional Principle of the Gripping Module

The gripping modules of the CRG series are servo-electrical two-finger parallel grippers with integrated gripping control, a high-performance brushless drive, and a high-resolution position measuring system, which has been developed for use in collaborative robot application. Tooth belt kinematics move and synchronize the base jaws, which are guided by rolling bearings. Due to the pre-positioning capability of the gripping fingers and the innovative gripping force control, the gripping modules of the CRG series can be used for a multitude of applications in modern automation. The module is supplied with power and connected to the process control directly via the integrated IO-Link interface. Rounded edges prevent any injuries when contacting with people thus ensures risk reduction for the design of collaborative applications. Integrated gripping force retention, which prevent slipping out of workpiece, even if the power supply to the gripper is interrupted unexpectedly, is a safe operation during any operation condition. Figure 8 shows the functional diagram of the CRG gripping modules.

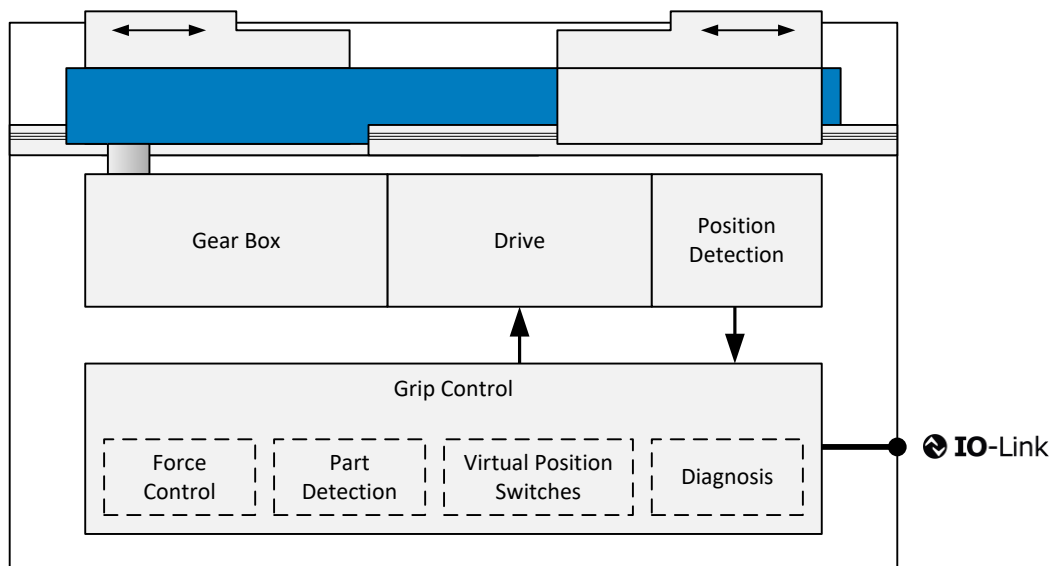

Figure 8: Functional diagram of the CRG gripping module

The integrated gripping control has a highly optimized gripped-part detection. Up to eight different parts can be pre-parameterized via IO-Link and gripped reliably. For each gripped part, a position window is set in which the grip must adjust itself. When the CRG grips in this area, its state changes from RELEASED to HOLDING, which signals a successful grip to the process control. As an alternative to the gripped-part detection, the position of the base jaws can also be monitored via freely parameterizable virtual position switches. To detect malfunctions, the CRG monitors all functionally relevant components, such as position sensors and drive, continuously and provides detailed diagnostic information via IO-Link during operation. Providing usage data via IO-Link makes needs-based maintenance possible. For this purpose, the CRG autonomously in-

dictates regular maintenance intervals and lubrication cycles through system events (IO-Link events). The cycles remaining until the next maintenance interval can be queried from the gripping module for better planning efficiency.

The gripping module has a rigid case made of high-strength aluminum. The base jaws are guided by double roller bearings and have a ground finger flange. Due to the nickel coated surface, the housing is electrically discharged and therefore suitable for use in ESD sensitive applications.

Operating states such as errors, warnings or interaction requirements can be visualized via the 360° luminous ring. So the operator can see at a glance the condition of the system and react accordingly. This allows a user friendly collaborative application.

7.1 Typical Application

Figure 9 shows a typical control-side setup with CRG series gripping modules that are accessed via PLC and a decentralized IO-Link field bus coupler. If you need assistance in selecting the IO-Link components, please contact our technical support.

⚠ Damage to the IO-Link master possible. Make sure that the IO-Link master can permanently provide the required operating current of the gripping module.

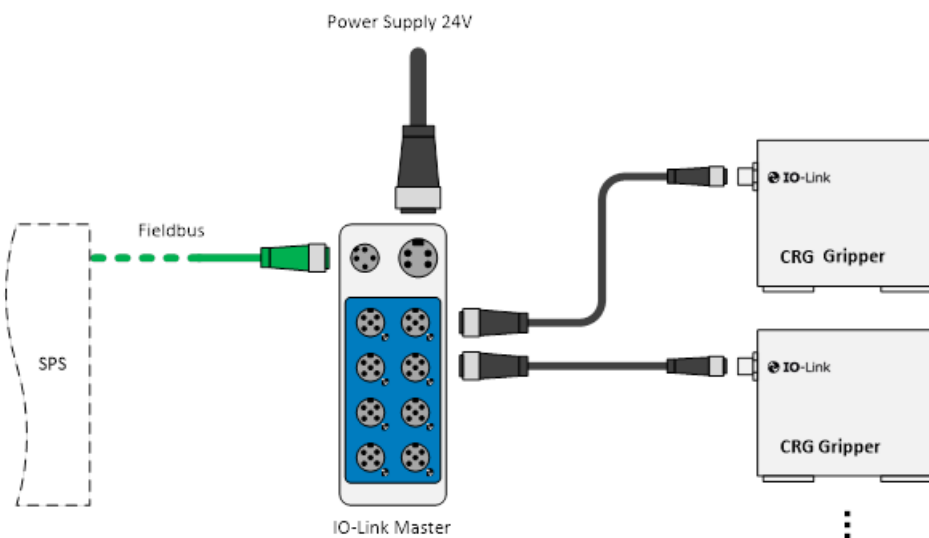

Figure 9: Typical application

7.2 Gripping force retention

The gripping module has an integrated gripping force retention which preserve approx. 80% of the gripping force even if the power supply to the gripper is interrupted. This effectively prevents slipping out of the

gripping part and thus minimize the risk of falling down or ejecting workpiece. The Gripping force retention works regardless of the gripping direction and required no configuration.

⚠ Damage to the gripping module possible: Do not move the gripping jaw by hand in the currentless state.

7.3 State visualization by luminous ring

A 360° luminous ring is integrated in the gripping module, which can be used to signal the user the different operating conditions. This cannot be only for the warnings and disturbances but also, especially in collaborative application, can be an advice on user interaction. For this purpose, the luminous ring can be extensively parameterized. That is also possible to adjust freely the lighting color, the animation (flashing, rotating or permanent light, etc.) and the animation speed. As the factory setting, different visualizations are parameterized, which can be used directly.

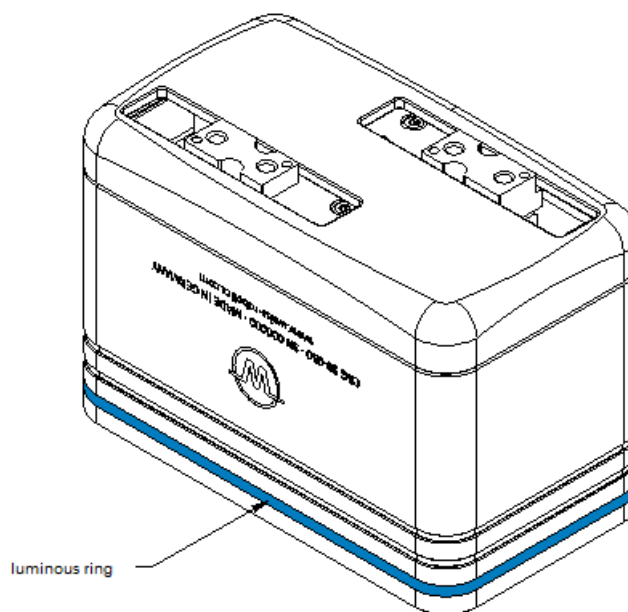

Figure 11: Position of the luminous ring

7.4 Non-volatile Memory

The gripping module has a non-volatile memory in which the following information is stored:

- Device-specific factory settings
- Parameterization of the gripping module

- Protocol memory (event log) of the last ten events
- Data for needs-based maintenance (gripping cycle count)

 The protocol memory can be read out via IO-Link (parameter index 0x100 to 0x109, cf. Table9).

8 Interface Description IO-Link

The interface description of the IO-Link interface is defined in the IO-Link Device Description (IODD) file that belongs to the gripping module. The IODD file that is needed for the configuration of the gripping module can be found on our website at <https://www.weiss-robotics.com/crg/> under “Downloads”.

8.1 Cyclic Process Data

 Please pay attention to the byte order. According to the IO-Link standard, data is transmitted in big-endian format.

8.1.1 Output Data (IO-Link Master to Gripping Module)

BYTE 0

15	14	13	12	11	10	9	8
VIS			PERMAGRIP	RES	HOME	EN	CMD

BYTE 1

7	6	5	4	3	2	1	0
INDEX							

Table 8 describes the cyclic process data (2 byte) that the gripping module expects from the IO-Link master.

BYTE 0

15	14	13	12	11	10	9	8
VIS			PERMAGRIP	RES	HOME	EN	CMD

BYTE 1

7	6	5	4	3	2	1	0
INDEX							

Table 8: Process data word IO-Link master to gripping module

VIS – Visualization Index (bit 15...13, UIntegerT)

This index selects one of eight preprogrammed visualization patterns for the luminous ring.

PERMAGRIP – Activate permanent gripping (bit 12, BooleanT)

If this bit is set, the gripping module automatically activates the gripping force retention (cf. chapter 7.2) when turning into HOLDING state. It can be used to permanently hold a workpiece without overheating the gripping module. The gripping force safety can be activated or deactivated as required by switching this bit while the HOLDING state is active.

In addition, when the gripping module is deactivated (EN command bit not active, the IDLE, RELEASED, NO PART, HOLDING, and FAULT status bits are set to 0), the gripper jaw locking can be activated or deactivated by switching the PERMAGRIP bit. When the locking is released, the gripper jaws can be moved manually, for example.

RES – Reserved data bit (bit 11)

This data bit is reserved and is currently not evaluated by the gripping module. Its value should always be set to 0 by the master.

HOME - Reference gripping module (bit 10, BooleanT)

If this bit is set and the gripping module is activated (EN = 1), a reference run is performed. In normal operation, this bit must be reset to 0. The reference run is described in chapter 9.3.

EN - Activate gripping module (bit 9, BooleanT)

This bit must be set so that movement commands can be executed. If the bit is not set, the drive is deactivated and the fingers are force-free.

CMD - Gripping command (bit 8, BooleanT)

With this bit, the gripping and releasing of parts is controlled. If the bit is set, the gripping module grips with the grip that has been selected via INDEX; otherwise the module releases a gripped part.

The actual direction of movement of the base jaws during GRIPPING and RELEASING is determined by the parameters RELEASE LIMIT and NO PART LIMIT, which are stored in the acyclic process parameters of the gripping module (cf. chapter 8.2.3).

INDEX - Grip index (bit 7...0, UIntegerT)

The grip index identifies one of four pre-parameterized grips (cf. chapter 9.6 and chapter 8.2.3), which is used for executing the next gripping command.

8.1.2 Input Data (Gripping Module to IO-Link Master)

Table 9 describes the cyclic process data word (4 bytes), which is transmitted from the gripping module to the IO-Link master.

BYTE 0

31	30	29	28	27	26	25	24
POS							

BYTE 1

23	22	21	20	19	18	17	16
POS							

BYTE 2

15	14	13	12	11	10	9	8
SW3	SW2	SW1	SW0	PARTLOST	PERMAGRIP	RES	MACT

BYTE 3

7	6	5	4	3	2	1	0
MAINT	TEMPWARN	TEMPFAULT	FAULT	HOLDING	CLOSED	OPEN	IDLE

Table 9: Process data word gripping module to IO-Link master

POS – Current position (bit 31...16, IntegerT)

Returns the current position of the base jaws in 1/100 mm.

SW0, SW1, SW2, SW3 - Virtual positions switches 0 to 3 (bit 15...12, BooleanT)

If the respective bit is set, the base jaws are within the parameterized position range of the respective virtual position switch.

PARTLOST – Lost workpiece detected (bit 11, BooleanT)

Indicates if a workpiece has been lost while holding (corresponds to a state transition from *HOLDING* to *NO PART*). Will be reset automatically when issuing a *RELEASE* command.

PERMAGRIP – Permanent gripping active (bit 10, BooleanT)

Acknowledges the PERMAGRIP control bit has been set to active by the master (cf. chapter 8.1.1)

RES – Reserved data bit (bit 9)

These data bits are reserved and are currently not used by the gripping module. Their value should be ignored by the master.

MACT – Motion active (bit 8, BooleanT)

Indicates that the gripper is moving

MAINT – Maintenance required (bit 7, BooleanT)

Shows whether the maintenance interval of the gripping module has been reached. You can find information on maintenance in chapter 10.



If maintenance has been performed, the MAINT bit must be acknowledged via a system command (cf. chapter 8.2.3.7). The maintenance counter is also reset.

TEMPWARN – Temperature warning (bit 6, BooleanT)

This bit is set when the temperature inside the gripping module falls below 0° C or exceeds 55° C. If the module exceeds the temperature regularly, you should check the heat dissipation of the gripping module and the ambient conditions.

The bit is automatically reset when the temperature is within the allowable range again (hysteresis: 2 °C).

TEMPFAULT – Temperature fault (bit 5, BooleanT)

When the temperature inside the gripping module exceeds 70° C, this bit is set. It is recommended to stop the gripping module and only start it again after it has significantly cooled down. If necessary, the heat dissipation of the gripping module should be checked.

The bit is automatically reset when the temperature falls below 68° C.



Temperatures exceeding 70° C may lead to malfunctions and to permanent damage of the gripping module.

FAULT – Device fault (bit 4, BooleanT)

When this bit is set, the gripping module is in error state. Information on the cause of the fault can be obtained by checking the active system events (cf. chapter 8.3) or by evaluating the event log.



For troubleshooting, see chapter 8.

HOLDING – Holding (bit 3, BooleanT)

Shows whether a part has been gripped. This is the case when the base jaws of the gripping module are blocked within the specified gripping range, i.e. between the parameterized RELEASE Limit and NO PART Limit, and the gripping force has been built up.

NO PART – No part found (bit 2, BooleanT)

When the base jaws of the gripping module reach the parameterized NO PART Limit or are moved beyond it, no part has been detected and this bit is set.

RELEASED – Part released (bit 1, BooleanT)

When the base jaws of the gripping module reach the parameterized RELEASE Limit or are moved beyond it, the part is considered released and this bit is set.

IDLE – Gripping module inactive (bit 0, BooleanT)

When this bit is set, the gripping module is inactive and force-free. No gripping commands can be executed.



For information on activating the gripping module, see chapter 9.6.1.

8.2 Acyclic Process Parameters and System Commands

For the operation of the gripping module, several acyclic process parameters can be set and queried. These process parameters comprise identification, configuration, and diagnosis data, as well as system commands. These data are addressed via index (8 or 16 bit) and subindex (8 bit). Some of the parameters are specified by the IO-Link standard; other parameters are device-specific or determined by the manufacturer. All parameters are defined in the IO-Link Device Description (IODD) file.

The acyclic process parameters can be set and read out during configuration with a suitable configuration software. This configuration software is available from the manufacturer of your IO-Link master or field bus coupler. Altering parameters and issuing system commands during operation is possible on many PLC systems with the respective function blocks (e.g. function block IO_LINK_CALL by Siemens). For further information, please contact the manufacturer of your IO-Link master, your PLC, or your field bus coupler.

8.2.1 Remanent Storage of Acyclic Process Parameters

Remanent Storage in the IO-Link Master

The gripping module supports remanent storage of acyclic process parameters in the IO-Link master (“Data Storage”, “Parameter Server”). If your IO-Link master also supports this function, the parameters set during configuration can be permanently stored in the IO-Link master. When the gripping module is activated, the stored parameter set is then automatically transferred from the IO-Link master to the gripping module. If the gripping module is exchanged, the stored parameter set can automatically be transferred to the new gripping module. It is then not necessary to configure the new module separately since the parameter set of the old module is automatically taken over.

For further information on the storage capabilities of your IO-Link master, please contact the manufacturer.

Remanent Storage in the Gripping Module

If your IO-Link master or your field bus coupler do not support permanent storage of acyclic process parameters, the parameters can also be stored remanently in the gripping module via a system command (cf. chapter 8.2.3.7). When the gripping module is disconnected from the power supply, the acyclic process parameters are preserved and are still available after reconnecting. However, if the gripping module is exchanged, the new module must be configured anew.

⚠ If you want to store the configuration remanently only in the gripping module, it could be necessary to deactivate the function “Data Storage” or “Parameter Server” on your IO-Link master. Otherwise the configuration stored in the gripping module will be overwritten by the IO-Link master at startup.

8.2.2 Standardized Acyclic Process Parameters

Table 10 lists the acyclic process parameters defined in the IO-Link standard that are supported by the gripping module. You can find more information on the meaning and use of the individual parameters in the IO-Link System Description⁴, which can be obtained from the IO-Link Community⁵.

Index	Function	Access	Data type	Description
0x02	System Command	Write only	UIntegerT(8)	<i>Execution of system commands</i>
0x0C	Device Access Locks	Read/write	RecordT	<i>Standardized device protection function</i>
0x10	Vendor Name	Read only	StringT	<i>Manufacturer name</i>
0x11	Vendor Text	Read only	StringT	<i>Manufacturer text</i>
0x12	Product Name	Read only	StringT	<i>Product name</i>
0x13	Product ID	Read only	StringT	<i>Product ID</i>
0x14	Product Text	Read only	StringT	<i>Product text</i>
0x15	Serial Number	Read only	StringT	<i>Serial number</i>
0x16	Hardware Revision	Read only	StringT	<i>Hardware revision</i>
0x17	Firmware Revision	Read only	StringT	<i>Firmware revision</i>
0x20	Error Count	Read only	UIntegerT(16)	<i>Number of errors since the start or reset of the gripping module</i>
0x24	Device Status	Read only	UIntegerT(8)	<i>Device status</i>
0x25	Detailed Device Status	Read only	ArrayT of OctetStringT3	<i>Detailed device status</i>

⁴ IO-Link Interface and System Specification, appendix B

⁵ <http://www.io-link.com>

8.2.3 Device-specific Acyclic Process Parameters

Configuration and diagnosis of the gripping module are performed via device-specific acyclic process parameters. You can find an overview on the parameters in chapter 12.

8.2.3.1 Motion Parameters

Override Gripping Speed in Percent

Decreases or increases the gripping speed, which has been automatically calculated from the specified gripping force. The necessary gripping speed is automatically determined by the gripping module and is optimized for a hard grip (steel on steel), see chapter 5.1.2. This predefined value is equivalent to 100%. The set value is valid for all grips.

 **Damage to the gripping module and to the gripped part possible. Excessive gripping speed can lead to rebound effects and heightened force peaks (gripping impulse) during gripping.**

 **Uneven movement (“clattering”) possible when gripping speed is insufficient.**

Address

Index 0x0040, Subindex 0x01

Data Type

UIntegerT(8) - Value range: 10 to 200

Factory Setting

100

Example:

Gripping with 100% of the calculated gripping speed: Set the value 100.

Gripping with double the calculated gripping speed: Set the value 200.

Override Release Speed in Percent

Limits the finger speed during releasing of the grip. By default, the grip is released with maximum speed. The set value is valid for all grips.

Address

Index 0x0040, Subindex 0x02

Data Type

UIntegerT(8) - Value range: 10 to 100

Factory Setting

100

Example:

Traversing with 10% of the maximum speed: Set the value 10.

Traversing with the maximum speed: Set the value 100.

Reverse Reference Run Direction

By default, the gripping module performs its reference run (chapter 9.3) outwards. By setting this value to "TRUE", the direction of the reference run can be reversed so the gripping module references inwards.

Address

Index 0x0040, Subindex 0x03

Data Type

BooleanT

Factory Setting

FALSE

Example:

Reference run inwards: Set the value "TRUE".

8.2.3.2 Grip Parameters

Four grips can be pre-parameterized. The factory settings depend on the build module type and are shown in Table 11.

All grips have the same scope of functions and have the following parameters:

NO PART Limit

Indicates the NO PART Limit for the respective grip. When performing a grip, the gripping module tries to position the base jaws on this target position. If the base jaws block due to a gripped part before the NO PART Limit is reached, the part is considered gripped (gripping state HOLDING). When the NO PART Limit is reached, the part is considered not gripped (gripping state NO PART). The position is indicated in 1/100 mm.

Address

Grip 0: Index 0x0060, subindex 0x01

Grip 1: Index 0x0061, subindex 0x01

Grip 2: Index 0x0062, subindex 0x01

Grip 3: Index 0x0063, subindex 0x01

Grip 4: Index 0x0064, subindex 0x01

Grip 5: Index 0x0065, subindex 0x01

Grip 6: Index 0x0066, subindex 0x01

Grip 7: Index 0x0067, subindex 0x01

Data Type

IntegerT(16)

Factory Setting

See Tab11

Example:

The nominal gripping position during external gripping of a part is 7 mm; the tolerance is set to 2 mm. The NO PART Limit must therefore be set to 5 mm, and the parameter must be set to 500.

RELEASE Limit

Indicates the RELEASE Limit for the respective grip (prepositioning). This is the target position for releasing the grip. When it is reached, the gripped part is considered released (gripping state RELEASED). The position is indicated in 1/100 mm.

Address

Grip 0: Index 0x0060, subindex 0x02

Grip 4: Index 0x0064, subindex 0x02

Grip 1: Index 0x0061, subindex 0x02

Grip 5: Index 0x0065, subindex 0x02

Grip 2: Index 0x0062, subindex 0x02

Grip 6: Index 0x0066, subindex 0x02

Grip 3: Index 0x0063, subindex 0x02

Grip 7: Index 0x0067, subindex 0x02

Data Type

IntegerT(16)

Factory Setting

See Table 11

Example:

The RELEASE Limit for external gripping of a part is at 10 mm: Set the value 1000.

Gripping Force

Determines the required gripping force as a percentage of the nominal gripping force. The gripping speed is also determined via the gripping force, see chapter 5.1.2.



The recommended minimum gripping force is 50% of the nominal gripping force. If you want to work with lower gripping forces, you must carry out tests in advance. Keep batch-to-batch variations in mind.

Address

Grip 0: Index 0x0060, subindex 0x03

Grip 4: Index 0x0064, subindex 0x03

Grip 1: Index 0x0061, subindex 0x03

Grip 5: Index 0x0065, subindex 0x03

Grip 2: Index 0x0062, subindex 0x03

Grip 6: Index 0x0066, subindex 0x03

Grip 3: Index 0x0063, subindex 0x03

Grip 7: Index 0x0067, subindex 0x03

Data Type

UIntegerT(8)

Factory Setting

See Table 11.

Example:

Gripping with nominal gripping force: Set the value to 100.

Gripping with minimal gripping force: Set the value to 25.

Factory Setting

The following grip parameters are preset for all grips:

Module Type	NO PART Limit	RELEASE Limit	Gripping force
CRG 30-050	50 (0.5 mm)	4950 (49.5 mm)	100%
CRG 200-085	50 (0.5 mm)	8450 (84.5 mm)	100%

Table 11: Factory settings of the grip parameters depending on module type

8.2.3.3 Virtual Position Switches

The gripping module has four virtual position switches. All position switches have the same scope of functions and can be set up via following parameters:

Switch Position

Indicates the center position of the switching range in 1/100 mm.

Address

Position switch 0: Index 0x0090, subindex 0x01

Position switch 1: Index 0x0091, subindex 0x01

Position switch 2: Index 0x0092, subindex 0x01

Position switch 3: Index 0x0093, subindex 0x01

Data Type

IntegerT(16)

Factory Setting

0 (0 mm)

Example:

The center position of the virtual position switch is 5 mm: Set the value 500.

Width of the Switching Range

Indicates the width of the switching range in 1/100 mm. The switching range is arranged symmetrically to the switch position.

Address

Position switch 0: Index 0x0090, subindex 0x02

Position switch 1: Index 0x0091, subindex 0x02

Position switch 2: Index 0x0092, subindex 0x02

Position switch 3: Index 0x0093, subindex 0x02

Data Type

UIntegerT(16)

Factory Setting

200 (2 mm)

Example:

The width of the switching range is 1 mm: Set the value to 100.

8.2.3.4 Visualization with luminous ring

The gripping module has a luminous ring that can be used to visualize different states of the application. For that purpose, eight visualization patterns can be parameterized. You can choose the animation, the color and the speed.

Animation

Choose the desired animation. The following animations are available:

Value	Animation
0	GRIPPING STATE
1	OFF
2	ON
3	FLASHING
4	PULSATION
5	ROTATING LIGHT CLOCKWISE
6	ROTATING LIGHT COUNTER CLOCKWISE
7	INNWARD

Value	Animation
8	OUTWARD
9	POSITION
10	LEFT SIDE FLASHING
11	RIGHT SIDE FLASHING
12	FRONT SIDE FLASHING
13	BACK SIDE FLASHING
14	FANCY RAINBOW ROATATING LIGHT

Table 12: Available animationen

Address

Visualization 0: Index 0x0080, Subindex 0x01

Visualization 1: Index 0x0081, Subindex 0x01

Visualization 2: Index 0x0082, Subindex 0x01

Visualization 3: Index 0x0083, Subindex 0x01

Visualization 4: Index 0x0084, Subindex 0x01

Visualization 5: Index 0x0085, Subindex 0x01

Visualization 6: Index 0x0086, Subindex 0x01

Visualization 7: Index 0x0087, Subindex 0x01

Data Type:

UIntegerT(8)

Factory Setting

See table 15

Example:

The animation should be as a clockwise rotating light: set the value 5

Color

Choose color for visualization. Following colors are available:

Value	Color
0	WHITE
1	RED
2	GREEN
3	BLUE
4	YELLOW
5	CYAN
6	MAGENTA

Table 13: Available color

Value	Color
7	ORANGE
8	LIGHT GREEN
9	AQUAMARIN
10	AZURE BLUE
11	VIOLET
12	PINK

! For animations 0(GRIPPING STATE) and 14(RAINBOW) the color setting is ignored.

Address

- Visualization 0: Index 0x0080, Subindex 0x02
- Visualization 1: Index 0x0081, Subindex 0x02
- Visualization 2: Index 0x0082, Subindex 0x02
- Visualization 3: Index 0x0083, Subindex 0x02
- Visualization 4: Index 0x0084, Subindex 0x02
- Visualization 5: Index 0x0085, Subindex 0x02
- Visualization 6: Index 0x0086, Subindex 0x02
- Visualization 7: Index 0x0087, Subindex 0x02

Data Type:

UIntegerT(8)

Factory Setting

See table 15

Example:

The animation should be a clockwise running light: set the value 2

Speed

Specifies the animation speed. The following speed values are available:

Value	Speed
0	STOP
1	SLOWEST
2	SLOWER
3	SLOW

Value	Speed
4	MEDIUM
5	FAST
6	FASTER
7	FASTEST

Table 14: Available animation speed

! For animations 0 (GRIPPING STATE), 1 (OFF) and 2 (ON), the set speed is ignored. The speed 0(STOP) causes a permanent light when animation 3,4 and 9-13 are blinking.

Address

Visualization 0: Index 0x0080, Subindex 0x03

Visualization 1: Index 0x0081, Subindex 0x03

Visualization 2: Index 0x0082, Subindex 0x03

Visualization 3: Index 0x0083, Subindex 0x03

Visualization 4: Index 0x0084, Subindex 0x03

Visualization 5: Index 0x0085, Subindex 0x03

Visualization 6: Index 0x0086, Subindex 0x03

Visualization 7: Index 0x0087, Subindex 0x03

Data Type:

UIntegerT(8)

Factory Setting

See table 15

Example:

The animation should be adjusted at medium speed: set the value 4

Factory Setting

The following visualization are preset.

Index	Meaning	Animation	Color	Speed
0	Gripping state	0 (Gripping State)	-	-
1	OK	2 (ON)	2 (GREEN)	-
2	Warning	2 (ON)	7 (ORANGE)	-
3	Error	2 (ON)	1 (RED)	-
4	Idle	5 (ROATING LIGHT CCW)	0 (WHITE)	4 (MEDIUM)
5	Busy	5 (ROATATING LIGHT CCW)	2 (GRÜN)	4 (MEDIUM)
6	User interaktion	5 (ROTATING LIGHT CCW)	3 (BLAU)	4 (MEDIUM)
7	Alarm	3 (FLASHING)	1 (RED)	7 (Fastest)

Table 15: Factory setting for illuminated ring visualisation pattern

8.2.3.5 Diagnosis Parameters***Duration of the Last Successful Gripping Operation Visualization with illuminated ring***

Indicates the duration of the last successful gripping operation in milliseconds.

Address

Index 0x00A0, subindex 0x01

Data Type

UIntegerT(16)

Factory Setting

(not available)

Example:

The last gripping operation took 42 ms. Reading out the parameter gives the result 42.

Duration of the Last Successful Releasing Operation

Indicates the duration of the last successful releasing operation in milliseconds.

Address

Index 0x00A0, subindex 0x02

Data Type

UIntegerT(16)

Factory Setting

(not available)

Example:

The last releasing operation took 116 ms. Reading out the parameter gives the result 116.

Current Module Temperature

Indicates the current temperature inside the gripping module in 1/10 °C.

Address

Index 0x00A0, subindex 0x03

Data Type

IntegerT(16)

Factory Setting

(not available)

Example:

A read-out value of 451 means a temperature of 45.1 °C.

Cycle Count

Indicates the total count of gripping cycles performed.



Since the gripping module only saves the current cycle count remanently after every 1000 cycles, the actual cycle count may differ from the displayed count.

Address

Index 0x00A0, subindex 0x04

Factory Setting

(not available)

Data Type

UIntegerT(32)

Cycles Remaining until Next Maintenance

Indicates the remaining gripping cycles until the next maintenance of the module. Negative values indicate that the maintenance interval has been exceeded.

Address

Index 0x00A0, Subindex 0x05

Data Type

IntegerT(32)

Factory Setting

(not available)

Example:

A read-out value of 200281 indicates that there are approximately 200281 cycles left until the next maintenance of the gripping module.

A read-out value of -50112 means that the maintenance interval has been exceeded by 50112 gripping cycles.

8.2.3.6 Protocol Memory

The protocol memory comprises ten entries, which can be read out via the device-specific acyclic process parameters. All entries are identical and are structured as follows:

Time Stamp

System time when the event occurs, measured in seconds since the boot-up of the module.

Address

Index 0x0100 (oldest entry) to 0x0109 (newest entry), subindex 0x01

Data Type

UIntegerT(32)

Factory Setting

0 (0 s)

Example:

A read-out value of 110678 indicates that the logged event occurred 110678 seconds or approximately 31 hours after the start.

Message Text

Returns the message text of the protocol entry. This text has a maximum of 140 characters. If there is no event logged at the queried index of the protocol, reading out the parameter returns the character string “(not set)”.

Address

Index 0x0100 (oldest entry) to 0x0109 (newest entry), subindex 0x02

Data Type

StringT(140)

Factory Setting

“(not set)”

Example:

A temperature error event returns the message text “Temperature Error. Please check device.”.

8.2.3.7 Extended Configuration Parameters

Maintenance Interval

Sets the number of gripping cycles for the maintenance interval.

This value is preconfigured by the manufacturer and doesn't need to be changed for normal operation. For certain applications, however, it might be useful to adjust the maintenance interval according to the environmental conditions of the gripping process.



Please note that the number of gripping cycles performed by the module is only saved remanently every 1000 cycles. This means that the module might have performed much more gripping cycles when reaching the maintenance interval than indicated by the cycle counter.

Address

Index 0x0140

Data Type

UIntegerT(32)

Factory Setting

2,000,000

8.2.4 System Commands

System commands are issued by writing the respective code (1 byte) at index 0x02 of the standardized process parameters (cf. chapter 8.2.2). If necessary, the system commands can be issued directly via the configuration software of the IO-Link master. The following commands are available:

Restarting the Gripping Module (Code 0x80)

With this command, you can restart the module without having to disconnect it from the power supply (warm start).

 **Process parameters that are not stored remanently are lost during a warm start.**

Reset to Factory Settings (Code 0x82)

With this command, the configuration of the gripping module can be reset to the factory settings.

 **All altered process parameters are overwritten with the standard setting.**

Acknowledge Maintenance (Code 0xB0)

With this command, you can confirm that the device has undergone maintenance. When the module signals that maintenance is necessary (in the cyclic process data word, cf. chapter 8.1.2, or via system event, cf. chapter 8.3), this command must be executed after maintenance has been performed. The maintenance count is then reset, and with it the system event and the respective bit in the cyclic process data word.

Save Configuration Remanently (Code 0xE0).

With this command, you can save the current configuration of the gripping module remanently. In case of power loss, the parameterization is still available.

 **For more information on remanently saving the configuration, see chapter 8.2.1.**

8.3 System Events (IO-Link Events)

Table 16 describes the system events that can be triggered by the gripping module.

 **For troubleshooting, see chapter 11.4.**

Code	Event	Description
0x0000	No Malfunction	No more malfunction. Previous faults were resolved.
0x1000	General Malfunction	Triggered when there is a general malfunction that cannot be specified further, e.g. in the event of a restart after watchdog reset. Further information can be found in the event log, if applicable.

Code	Event	Description
0x1800	Motion Fault	Triggered when the base jaws do not move despite a motion command due to a blocked or defective drive.
0x4000	Temperature Fault	The temperature inside the gripping module exceeds 70 °C. It is recommended to stop the gripping module and only start it again after it has significantly cooled down. If necessary, the heat dissipation of the gripping module should be checked.  Continuing operation despite a temperature fault may lead to malfunctions and to permanent damage of the gripping module.
0x4210	Device Temperature Overrun	The temperature inside the gripping module exceeds 55 °C. The heat dissipation of the gripping module should be checked.
0x4220	Device Temperature Underrun	The temperature inside the gripping module falls below 0 °C.
0x5010	Component Malfunction	Triggered when there is a malfunction during startup or operation of the gripping module.
0x5011	Non-Volatile Memory Loss	<i>Memory error in the configuration memory</i> Triggered when a memory error in the configuration memory is detected during the startup of the gripping module.
0x8C00	Technology Specific Application Fault	Motor current out of the allowable range or measured values of the position sensor invalid.
0x8C41	Maintenance Required	The gripping module has reached or exceeded the cycle count upon which the next maintenance is required. Maintenance must be carried out.

Table 16: System events (IO-Link events)

9 Control of the Gripping Module

The gripping module is accessed via a standardized data format in accordance with IO-Link specification V1.1 (IEC 61131-9). This is a powerful point-to-point communication protocol in which the process data are cyclically exchanged between the IO-Link master and the gripping module.

The gripping module is also parameterized via IO-Link. This can be performed with the configuration software of the IO-Link master or with the DC-IOLINK device configurator by Weiss Robotics, which is available separately.

 **The IO-Link Device Description (IODD file) that is needed for the configuration of the gripping module can be found on our website at <https://www.weiss-robotics.com/crg/>.**



A configuration example based on SIEMENS TIA Portal can be found in chapter 12.

9.1 Gripping Commands

The movement of the base jaws is controlled via the command bits of the cyclic process data. The following commands are available:

ENABLE

The gripping module is activated, and the drive is switched on. The selected command GRIP, RELEASE, or REFERENCE is executed.

DISABLE

The gripping module is deactivated, and the drive is switched off. The base jaws are force-free.

RELEASE

The jaws are opened, and the gripped part is released.

GRIP

The jaws are closed, and the part is gripped.

HOME

A reference run is performed for the gripping module.



The direction of movement of the base jaws during GRIPPING and RELEASING is determined by the parameterization of the grip.

After the start of the gripping module, the drive is initially deactivated and the gripping force retention is active. To move the base jaws, the gripping module must be activated and a GRIP and RELEASE be executed. The first valid command deactivates the gripping force retention.

9.2 Position Sensors

The gripping module has an integrated position measurement system with which the position of the base jaws is measured relatively. The position value corresponds to the spacing of the two base jaws. The inner limit corresponds to the value 0 mm. Figure 12 shows the correlation between the position value and the position of the base jaws using the example of the CRG 30-050. The current position value is transmitted in the cyclic process data.

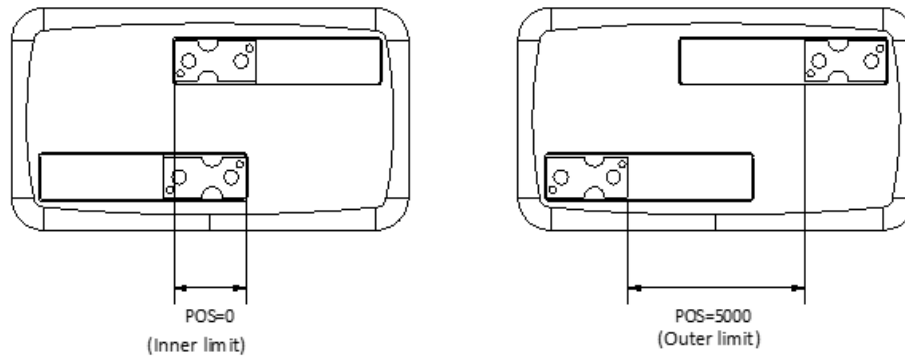

Figure 12: Example: position value CRG 30-050

9.3 Reference Run

In addition to the relative position measurement system, the gripping module CRG series has an absolute measuring system which provide the position of the base jaws directly after activating. Therefore a reference movement is not required. Nevertheless, the module can be referenced during operation. For this purpose, the module moves the base jaws with defined force and speed to the outer limit and uses this position as a reference value.

⚠ Keep the traversing range of the fingers free during the reference run to avoid collisions and faulty referencing.

If an individual application makes an outwards reference run impossible, e.g. if it would lead to a collision with a part or with the environment, the direction of the reference run can be reversed and the inner limit can be used (see chapter 8.2.3.1).

9.4 Virtual Position Switches

To detect different end positions, up to four virtual position switches can be parameterized. These position switches are realized in the control software of the gripping module (“virtually”). Their switching status is transmitted via the cyclic process data of the gripping module.

You can determine the center position and the width of the detection range for each position switch. The position switches do not save their status but provide a momentary signal. To detect an end position reliably, it must be ensured mechanically that the fingers block in the position that is to be detected, e.g. by a mechanical end stop or by the gripped part.

! Merely traversing a position switch cannot be detected reliably due to the time-discrete sampling.

9.5 Gripping State

Besides detecting end positions via virtual position switches (cf. chapter 9.3), the gripping module also provides the “gripping state”. The gripping state is generated by the integrated gripped-part detection and is transmitted to the cyclic process control via the cyclic process data. It can be used for the sequence control of the handling process. Table 17 lists all possible gripping states. After startup, the module is in a special “NOT INITIALIZED” state. The gripping module remains in this state until a reference run has been initiated.

State	State flag	Description
IDLE	IDLE = 1	Gripper Is Idle The gripping module is inactive, and the fingers are force-free.
RELEASED	RELEASED = 1	Part Released The part has been released, i.e. the parameterized RELEASE Limit has been reached. The base jaws remain position-controlled in this position with reduced force.
NO PART	NO PART = 1	No Part Gripped No part has been detected while gripping, i.e. the parameterized NO PART Limit has been reached. The base jaws remain position-controlled in this position with reduced force.
HOLDING	HOLDING = 1	Part is being held. The gripping module has been blocked between the parameterized RELEASE Limit and NO PART Limit, and the base jaws do not move. The part is held with the specified force; gripped-part monitoring is activated.
ERROR	FAULT = 1	An Error Has Occurred An internal error that prevents the module from functioning correctly has occurred. For information on error causes, see chapter 11.4. Additionally, a system event has been triggered, see Table16.

Table 17: Gripping states

In regular operation, depending on the command executed last and the current position of the base jaws, one of four gripping states can be reached: IDLE, RELEASED, NO PART, or HOLDING. The FAULT state indicates a device error. The possible transitions between the states are depicted in Figure 13.

A change of state is initiated by the gripping commands GRIP/RELEASE and ENABLE/DISABLE, which are set by the master via the cyclic process data. When the gripping module receives a new command, the command is executed and the gripping state changes accordingly. Every command leads to a change of state so the completion of a command can be identified by waiting for a change of state.

Thus, the gripping state provides a simple opportunity to monitor the gripping process in the controlling PLC or robot control. After a new gripping command has been issued, you must just wait for the change of the gripping state to identify the correct or incorrect execution of the command and take the next process step accordingly.

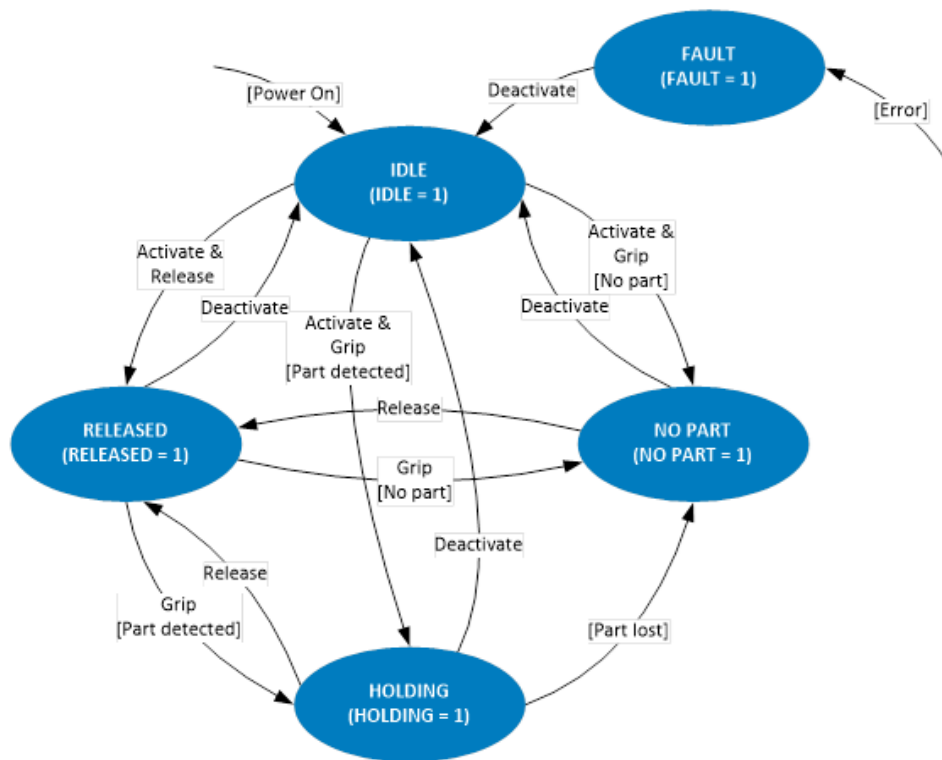

Figure 13: Gripping state

9.6 Parameterizable Grips

Four different grips can be parameterized for the gripping of different parts. The grip is selected via the grip index, which is transmitted by the cyclic process data, and is performed with the gripping commands GRIP or RELEASE.

As depicted in Figure 14, for parameterization, a position window must be determined by the RELEASE Limit and NO PART Limit for each grip. The part to be gripped must be within this window. When the base jaws are blocked within this window during GRIPPING, the gripping module detects a valid grip and changes to the gripping state HOLDING. When the base jaws reach the specified NO PART Limit, the gripping state changes to NO PART to signal that no part has been gripped.

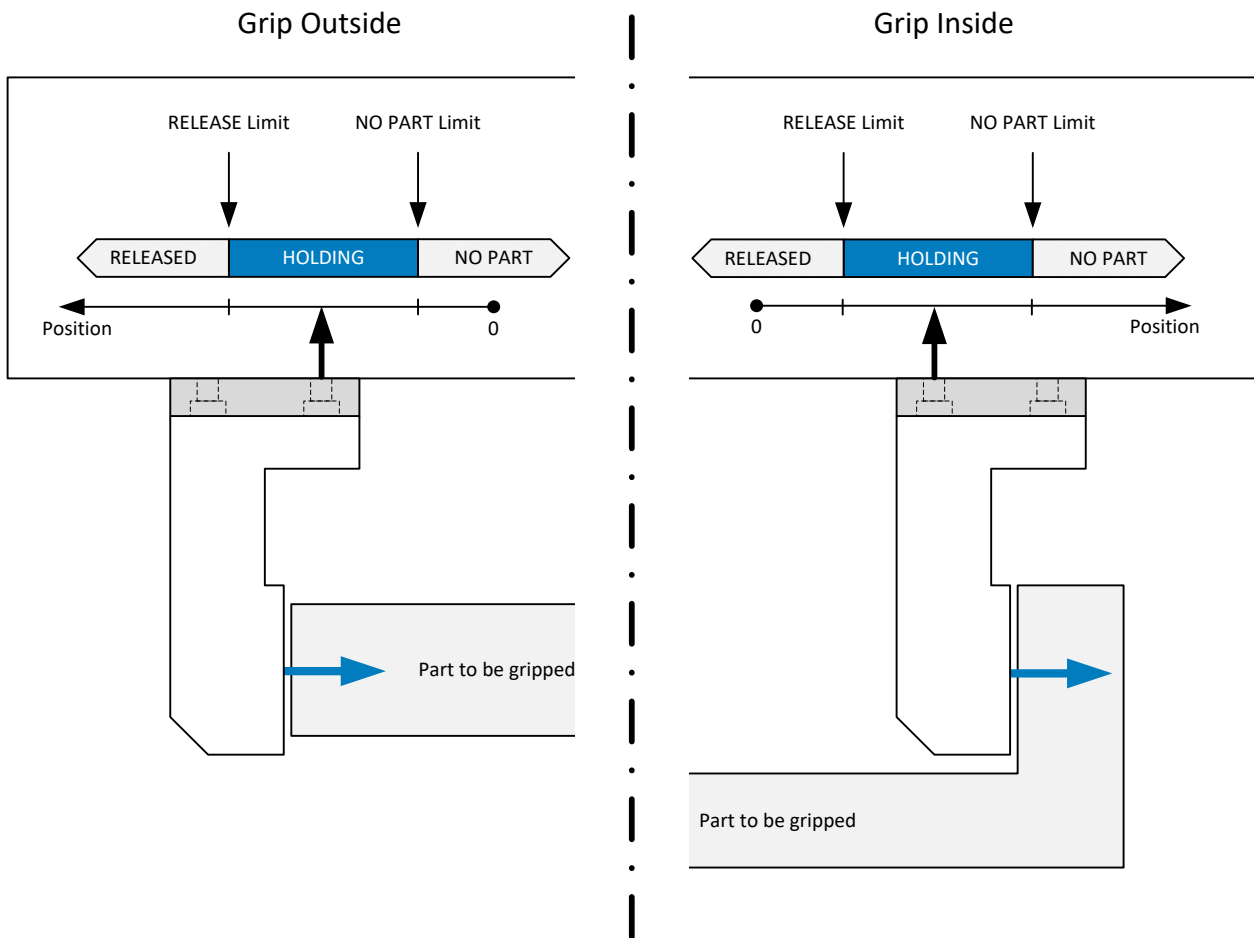

Figure 14: Gripping area and gripping direction

- ! **If the base jaws are blocked outside the position window, e. g. at the end stop of the movement, the gripped part is considered released or no part has been detected, depending on the direction of movement.**
- ! **Danger of collision. If the gripping area is not sufficiently large, parts that are too small or too large may be gripped, although the gripping state is NO PART or RELEASED. If in doubt, please check the current jaw position.**
- ! **The “RELEASE limit” and “NO PART limit” parameters must be selected with a sufficient safety margin to the end stops. Gripping and releasing at the end stops must be avoided.**

9.6.1 Gripping Direction

The gripping direction is determined by the RELEASE Limit and NO PART Limit. When the position for the NO PART Limit is smaller than that for the RELEASE Limit, the gripping module performs an inward grip (Figure14,

“Gripping Outside”). When the position for the NO PART Limit is larger than that for the RELEASE Limit, the gripping module performs an outward grip (Figure 14, “Gripping Inside”). Please note that the total stroke may deviate from its nominal value due to mechanical tolerances. This means that, even with the same position specification, the positions of the basic jaws may differ depending on the direction of the reference run performed beforehand.

9.7 Grip Part

The program sequence for gripping a part is Figure 15. The gripping module must be initialized and activated before it can perform a grip (see chapter 9.6.1). The gripping direction depends on the parameterization of the respective grip. The module detects the end of the gripping process or an error by continuously monitoring the gripping state. When the parameterized NO PART Limit has been reached, no part has been gripped and the base jaws remain at this position.

When an error has occurred during gripping, it must be acknowledged as described in chapter 7.

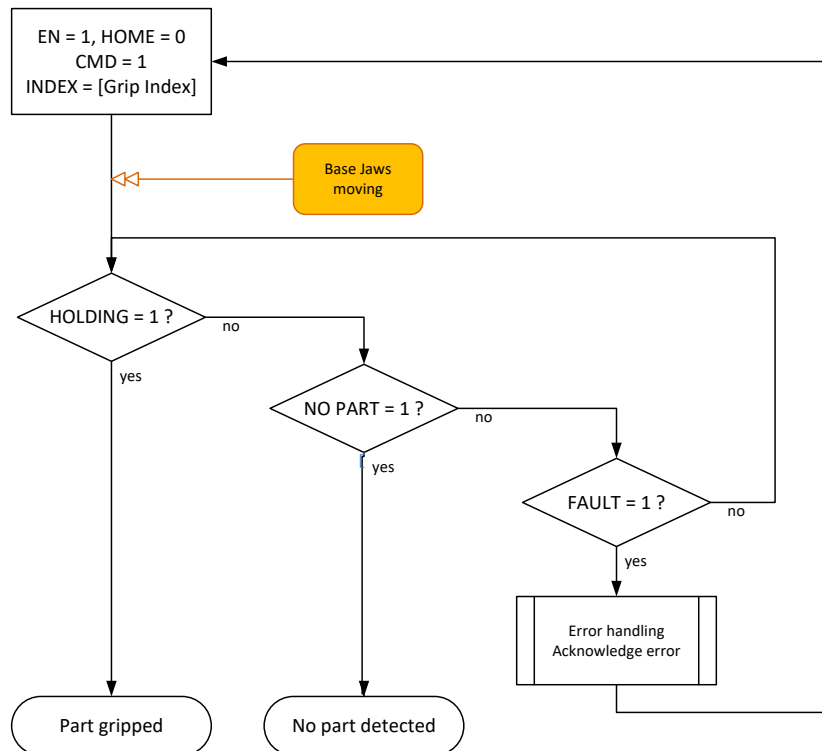

Figure 15: Program sequence gripping

9.7.1 Gripping with high gripping force or over a long period of time

When gripping with high gripping forces (> 60%) or over a long period of time (> 30 seconds), high thermal stress within the gripper module can occur. In these applications, the PERMAGRIP bit shall be set in the cyclic

process data (refer to section 8.1.1). This activates the gripping force retention in HOLDING state and the motor is switched off to minimize thermal power dissipation.

⚠️ Holding a workpiece with high gripping forces over a long period of time can lead to overtemperature errors and consequently to failure of the gripping module! In such applications, be sure to set the PERMAGRIP bit!

9.8 Release Part

In order to loosen a grip that has been performed before and to release the gripped part, the program sequence Figure 16 must be executed. Releasing the part is initiated by resetting the CMD flag. The direction of movement depends on the selected grip, which should not be changed while holding a workpiece (grip index during releasing = grip index during gripping).

! To switch between grips, first release the part and then change the grip index.

The gripped part is considered released (change from HOLDING state to RELEASED state) as soon as the base jaws have reached the RELEASE Limit. There they remain position-controlled, but with reduced force.

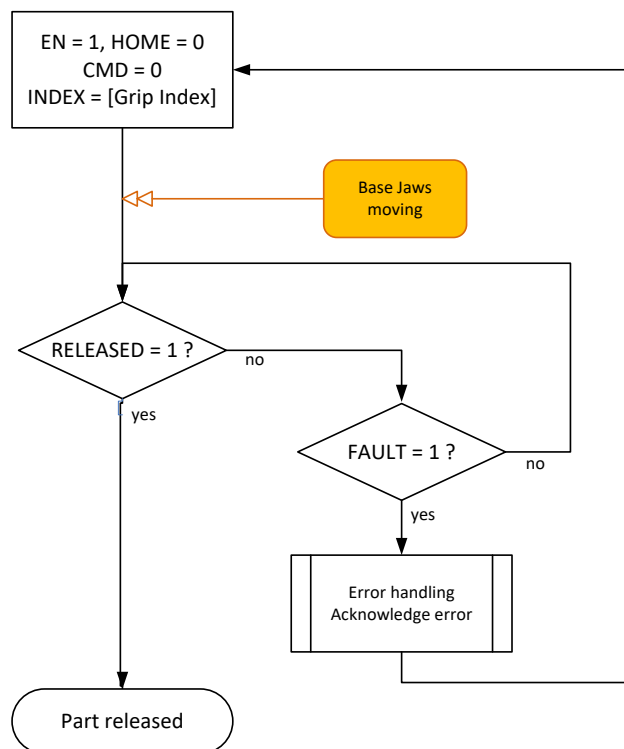

Figure 16: Program sequence release part

⚠️ Be sure to keep the travel area of the fingers clear during the release run to avoid collisions and damage to the gripping module.

9.9 Troubleshooting

When the gripping module is in the FAULT state during regular operation, an internal error has occurred that prevents the module from functioning correctly. Possible causes for errors are described in chapter 11.4. In addition to the FAULT state, a system event that specifies the cause of error is triggered, see Table 16.

! To acknowledge an error, the module must be deactivated and reactivated.

Figure 17 shows the program sequence that is required to acknowledge an error. If the error cannot be acknowledged, try to restart the gripping module by temporarily disconnecting it from the power supply. If the error persists, please contact the technical support of Weiss Robotics. The gripping module may be defective.

! Possible loss of parts. Move the module into a safe position before acknowledging the error.

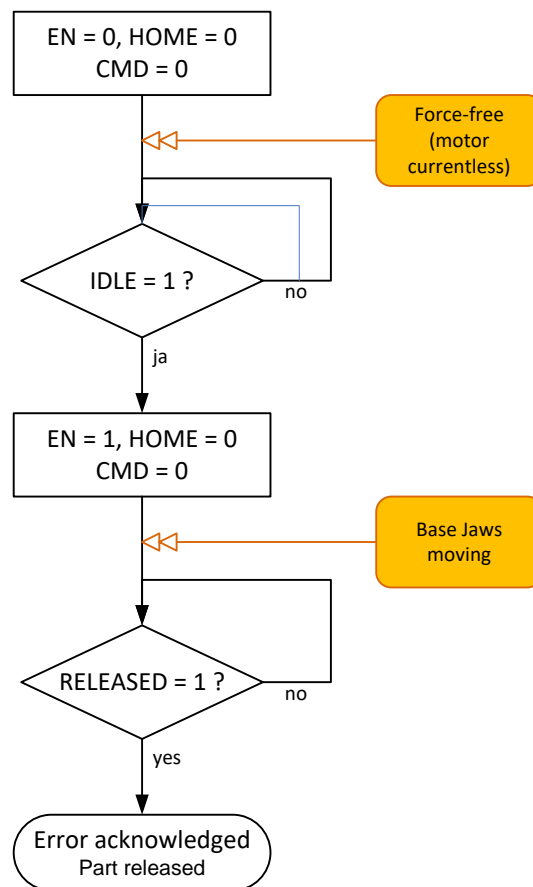

Figure 17: Program sequence acknowledging an error and releasing a part

9.10 Activating and Deactivating the Module (Setup Mode)

Especially when setting up the gripping process, it may be advisable to deactivate the gripping module. The fingers are then force-free, but the logic of the gripping module and the position detection are still active. Thus, e. g. gripping positions can be taught in manually, or parts can be extracted manually. The control sequences for both states are depicted in Figure 18.

⚠ Please follow the safety instructions when you work directly at the gripping module.

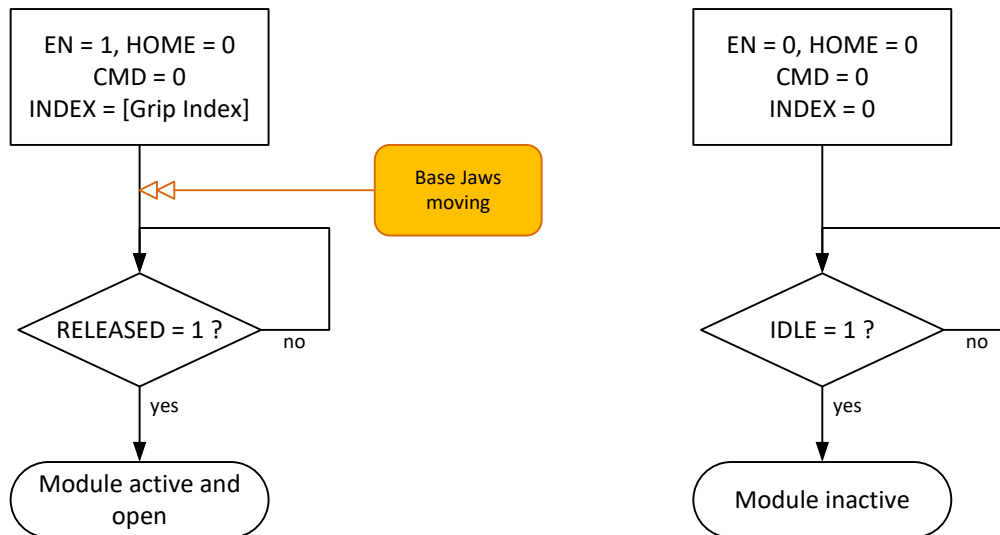

Figure 18: Program sequence to activate (left) and deactivate (right) gripping module

9.11 Gripping force retention

The gripping module has a gripping force retention which preserve approx. 80% of the gripping force even if the power supply to the gripper is interrupted. Thus slipping out of the gripping part is avoided even when the gripper is turned off while a part is being gripped

After switching on again, the gripping force retention is released by the first valid command and the corresponding command is executed. If this first valid command is a gripping command, the gripping force is rebuilt and the gripping state changes to the HOLD state.

9.12 Visualization with illuminated ring

The 360° luminous ring can be used to indicate different operating states. For this purpose, eight visualization patterns can be configured, which can be accessed via the process data. For each visualization pattern, the animation (flashing, running light, etc.), the light color and the animation speed can be defined. The gripping state is visualized on the default setting. Table 18 shows the visualization patterns for the respective gripping states.

Gripping state	Animation	Color
IDLE	Running light CCW	White
RELEASE	Outward/ Inward	Blue
NO PART	Outward/ Inward	Blue
HOLDING	On	Green
ERROR	Flashing	Red

Table 18: Visualization the gripping states

9.13 Design of the Gripping Process

The design of the gripping process determines the reliability of the production process. The following points have been proved to be helpful:

- Put the gripping point in the center of the stroke range of the base jaws by constructively designing the fingers if the process allows this.
- If possible, secure the position of the part by establishing a form-fit connection between the contact area of the finger and the contact area of the part to be gripped.
- Avoid inaccuracies in the contact with the part by constructing the contact areas accordingly.
- Use a compensatory element if traverse forces can occur at the gripping module due to gripping or positioning tolerances. That is the case, e.g., when a clamped part is to be picked up by a gripping module that has been positioned by a robot.
- Choose a large enough gripping range (recommended distance between RELEASE Limit and NO PART Limit ≥ 2 mm) to maximize the reliability of the gripping process.
- Always keep a distance to the stroke stop with the positions for the RELEASE Limit and the NO PART Limit so a secure grip detection is possible and the gripping module does not grip itself.
- During holding, the continuous application of the gripping force creates heat that must be dissipated from the gripping module. Make sure that the mounting surface has sufficient heat dissipation. Avoid permanent holding and do not block the fingers beyond the actual gripping process (e.g. by setting the RELEASE Limit outside the stroke range) in order not to heat up the module unnecessarily.
- Perform some idle strokes traversing the whole movement range every 1000 gripping cycles to ensure an even distribution of the lubricant in the linear guides.

The following application examples describe the realization of simple handling tasks and how to parameterize and use the gripping module via IO-Link accordingly.

9.13.1 Application Example External Gripping

Figure 19 shows an example of external gripping with the CRG 30-050 gripping module. An electrolytic capacitor is to be gripped at the casing and dropped into a fixture. The capacitor has a nominal diameter in the gripping area of 15 mm. The gripping fingers have been configured in such a way that the nominal diameter corresponds to a jaw spacing at the gripping module of 10 mm (half the total stroke). To ensure the reliability of the gripping process, a position tolerance of ± 1 mm is set. Due to the low weight of the part, the gripping force is set to 21 N. For the CRG 30-050, this means the gripping force is set to 70%. The part is parameterized as GRIP 0 of the gripping module. For this purpose, the following parameters are set via the configuration software of the IO-Link master or via the Weiss Robotics DC-IOLINK device configurator, which is available separately:

GRIP 0:

NO PART Limit (index 0x60, subindex 0x01):	900	(= 9.00 mm)
RELEASE Limit (index 0x60, subindex 0x02):	1100	(= 11.00 mm)
Gripping force (index 0x60, subindex 0x03):	70	(= 70%, corresponding to 21 N)

! If the module is parameterized via DC-IOLINK, the parameterized values must be stored remanently in the gripping module before it is deactivated, see chapter 8.2.1.



Figure 19: Gripping example external gripping

The gripping process is performed via the program sequences in Figure 15 (grip part) and Figure 16. (release part). Since GRIP 0 has been parameterized, the grip index 0 must be used in the program sequence. 0 was

selected as the visualization index to visualize the gripping state via the illuminated ring on the gripping module: In the released state, the illuminated ring shows an animation outwards in blue, if the part has been gripped correctly, the light shows green.

9.13.2 Application Example Internal Gripping

In a mounting process, a plain bearing bush is to be picked up and inserted with an CRG 30-050. Since the bush is to be inserted into a bore hole, it must be gripped from the inside. The gripping application is depicted in Figure 20. The fixing at the motion axes and possible compensatory elements are not depicted here. The bush with its inner diameter of 22 mm is gripped and aligned with the help of hardened pins (Figure 20, right view).

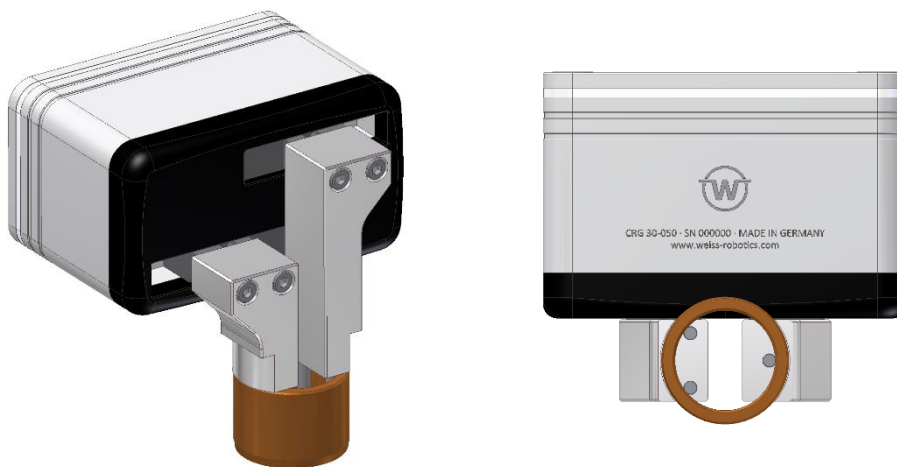

Figure 20: Application example internal gripping

The gripping fingers are designed in such a way that the part is held at a jaw position of 10 mm (half the total stroke of the gripping module). To ensure the reliability of the gripping process, a position tolerance of ± 1.5 mm is set. The gripping force should be the nominal gripping force.

Since GRIP 0 is already in use, the part is parameterized as GRIP 1 of the gripping module. For this purpose, the following parameters are set via the configuration software of the IO-Link master or via the Weiss Robotics DC-IOLINK device configurator, which is available separately:

GRIP 1:

NO PART Limit (index 0x61, subindex 0x01):	1150	(= 11.50 mm)
RELEASE Limit (index 0x61, subindex 0x02):	850	(= 8.50 mm)
Gripping force (index 0x61, subindex 0x03):	100	(= 100%, corresponding to 30 N)



If the module is parameterized via DC-IOLINK, the parameterized values must be stored remanently in the gripping module before it is deactivated, see chapter 8.2.1.

To grip the part, the control system performs the program sequence depicted in Figure 15. When the GRIP command is issued, the fingers move apart since the NO PART Limit is higher than the RELEASE Limit. To release the part, perform the program sequence depicted in Figure 16. Since GRIP 1 has been parameterized in this example, the grip index 1 must also be used for performing the program sequences mentioned above. As a visualization index, 0 was selected to visualize the gripping state via the illuminated ring on the gripping module: In the released state, the illuminated ring shows an animation inwards in blue; if the part is correctly gripped, it changes to green.

9.14 Function Block for Siemens TIA Portal

 For TIA portal, there is a function block available at <https://www.weiss-robotics.com/crg/> under “Downloads”. The documentation of the function block can be found in the downloaded file.

10 Maintenance and Cleaning

 **Damage to the gripping module due to inadequate lubrication possible. Perform some idle strokes traversing the whole movement range every 1000 gripping cycles and at least once a day to ensure an even distribution of the lubricant in the guides.**

Clean the gripping module in regular intervals with a dry cloth to remove all dirt and possible splinters. They typically build up below the belt cover. Remove the cover as depicted in Figure 21 to clean the module with a brush.

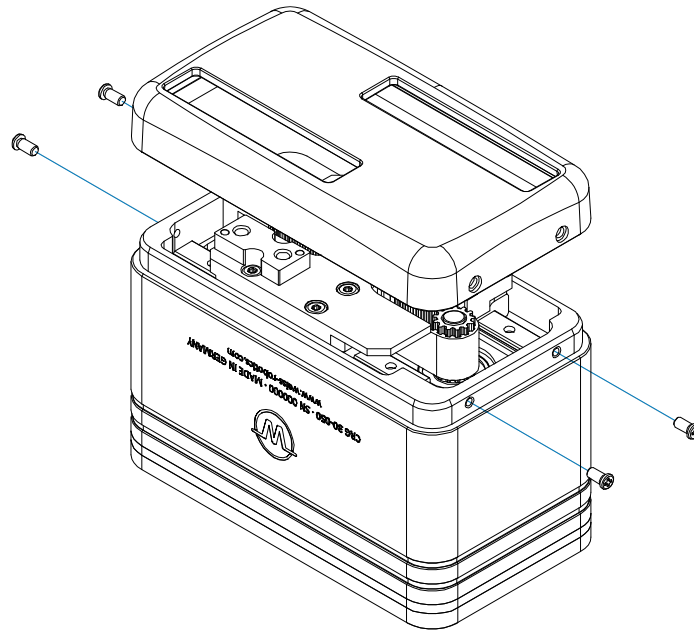

Figure 21: Removing the belt cover

⚠ The gripping module is factory-adjusted. Do not remove the base jaws and the belts.

The maintenance intervals must be adjusted to the surface and operating conditions. The following factors should be taken into account:

- Increased operating temperatures
- Condensation and perspiration water effects
- High vibration stress
- Use in a vacuum
- High-dynamics operation
- Effects from foreign substances (e.g. vapors, acids, etc.)

! The guides are lubricated for life. In individual cases, it might be necessary to relubricate them. Contact our support if you need advice.

10.1 Needs-based Maintenance

When the maintenance function is activated, the gripping module triggers a system event when the maintenance interval has been reached. In addition, the MAINT flag is set in the cyclic process data. The remaining cycles until the maintenance interval is reached can be queried via the acyclic process parameters (see chapter 8.2.3.45).

10.2 Resetting the Maintenance Interval Count

After successful maintenance, the interval count must be reset by acknowledging the maintenance (see chapter 8.2.3.7).

11 Troubleshooting

11.1 The Base Jaws Do Not Move

Possible Cause	Remedy
The operating voltage is too low, or the power supply is insufficient.	<ul style="list-style-type: none"> • Check the power supply. • Check the requirements of the power supply.
Communication with the module is not possible.	<ul style="list-style-type: none"> • Check the connections and communications cables. • Check compatibility with the IO-Link master (the gripping module only supports V1.1 masters).
Error message in the system	<ul style="list-style-type: none"> • Check the module's operating state. • The gripping module reports an error -> chapter 11.4. • Restart the gripping module. If the error occurs again, send the gripping module to Weiss Robotics with a repair order.
Failure of a component, e.g. through overload	<ul style="list-style-type: none"> • Send the gripping module to Weiss Robotics with a repair order. • Make sure the gripping module is only used according to the defined operating parameters.

11.2 Gripping Module Stops Abruptly or Does Not Complete the Entire Stroke

Possible Cause	Remedy
Wrong parameterization	<ul style="list-style-type: none"> • Check the parameterization.
Power supply interrupted	<ul style="list-style-type: none"> • Check the power supply.
No communication with the gripping module possible	<ul style="list-style-type: none"> • Check the connections and communications cables.
Error message in the system (the state display's light is red)	<ul style="list-style-type: none"> • Check the module's operating state. • The gripping module reports an error -> chapter 11.4.
Foreign objects in the motion system or module contaminated	<ul style="list-style-type: none"> • Deactivate the gripping module and check the mobility by moving the fingers manually. • Remove foreign parts. • Perform cleaning and maintenance.
Uneven mounting surface	<ul style="list-style-type: none"> • Check the evenness of the mounting surface.

11.3 No Communication with the Gripping Module

Possible Cause	Remedy
Power supply interrupted	<ul style="list-style-type: none"> Check the power supply.
The IO-Link connection cannot be established.	<ul style="list-style-type: none"> Check the connections and communications cables. Check the compatibility with the IO-Link master (the gripping module only supports V1.1 masters).

11.4 The Gripping Module Reports an Error

The state display's light is permanently red or flashes red. The gripping module has triggered a system event (IO-Link event according to table 16).

Error code of the gripping module	Remedy
Motion error	This error occurs when the base jaws do not move despite a movement command. If this error occurs repeatedly, the drive is defective. Send the gripping module to Weiss Robotics with a repair order.
Temperature fault	<p>The temperature inside the gripping module exceeds 70 °C. It is strongly recommended to stop the gripping module and only start it again after it has significantly cooled down.</p> <ul style="list-style-type: none"> Check the ambient conditions. Improve the heat dissipation. Shorten the holding cycles or reduce the gripping force. Make sure that there is a distance between the base jaws and the end stop in the RELEASED state. Reduce the heat input from outside. <p>The error is automatically reset when the gripping module has cooled down. The gripping module remains operational, but it is not recommended to continue operation.</p>
Memory error in the configuration memory	<p>The content of the configuration memory is inconsistent.</p> <ul style="list-style-type: none"> Restart the gripping module. If the error persists, please contact our technical support.
Component malfunction	<p>At least one control component required for operation could not be initialized.</p> <ul style="list-style-type: none"> Restart the gripping module. If the error persists, send the gripping module to Weiss Robotics with a repair order.
General error	<p>Restart by watchdog reset.</p> <ul style="list-style-type: none"> Acknowledge the error. If the error occurs regularly, please contact our technical support.

Technology-specific application error	Motor current out of the allowable range or measured values of the position sensor invalid. <ul style="list-style-type: none">• Restart the gripping module. If the error persists, send the gripping module to Weiss Robotics with a repair order.
--	---



For troubleshooting, see chapter 9.6.1.

12 APPENDIX A - Device-specific Process Parameters

Table 9 lists the device-specific process parameters of the gripping module. A detailed description can be found in chapter 8.2.3.

Index	Funktion	Zugriff	Subindex	Datentyp	Beschreibung	Werkseinstellung
0x40	Motion Parameter	Read /write	1	UIntegerT(8)	<i>Override gripping speed in percent</i>	100
			2	UIntegerT(8)	<i>Override gripping speed in percent</i>	100
			3	BooleanT(8)	<i>Reverse reference run direction</i>	false
0x60	Grip 0	Read /write	1	IntegerT(16)	<i>NO PART Limit in 1/100 mm</i>	see Table 11
			2	IntegerT(16)	<i>RELEASE Limit in 1/100 mm</i>	
			3	UIntegerT(8)	<i>Gripping force in percent</i>	
0x61	Grip 1	Read /write	1	IntegerT(16)	<i>NO PART Limit in 1/100 mm</i>	
			2	IntegerT(16)	<i>RELEASE Limit in 1/100 mm</i>	
			3	UIntegerT(8)	<i>Gripping force in percent</i>	
0x62	Grip 2	Read /write	1	IntegerT(16)	<i>NO PART Limit in 1/100 mm</i>	
			2	IntegerT(16)	<i>RELEASE Limit in 1/100 mm</i>	
			3	UIntegerT(8)	<i>Gripping force in percent</i>	
0x63	Grip 3	Read /write	1	IntegerT(16)	<i>NO PART Limit in 1/100 mm</i>	
			2	IntegerT(16)	<i>RELEASE Limit in 1/100 mm</i>	
			3	UIntegerT(8)	<i>Gripping force in percent</i>	
0x64	Grip 4	Read /write	1	IntegerT(16)	<i>NO PART Limit in 1/100 mm</i>	
			2	IntegerT(16)	<i>RELEASE Limit in 1/100 mm</i>	
			3	UIntegerT(8)	<i>Gripping force in percent</i>	

Index	Funktion	Zugriff	Subindex	Datentyp	Beschreibung	Werkseinstellung
0x65	Grip 5	Read /write	1	IntegerT(16)	<i>NO PART Limit in 1/100 mm</i>	
			2	IntegerT(16)	<i>RELEASE Limit in 1/100 mm</i>	
			3	UIntegerT(8)	<i>Gripping force in percent</i>	
0x66	Grip 6	Read /write	1	IntegerT(16)	<i>NO PART Limit in 1/100 mm</i>	
			2	IntegerT(16)	<i>RELEASE Limit in 1/100 mm</i>	
			3	UIntegerT(8)	<i>Gripping force in percent</i>	
0x67	Grip 7	Read /write	1	IntegerT(16)	<i>NO PART Limit in 1/100 mm</i>	
			2	IntegerT(16)	<i>RELEASE Limit in 1/100 mm</i>	
			3	UIntegerT(8)	<i>Gripping force in percent</i>	
0x80	Virtualization 0	Read /write	1	UIntegerT(8)	<i>Animation</i>	see Table 11
			2	UIntegerT(8)	<i>Color</i>	
			3	UIntegerT(8)	<i>Speed</i>	
0x81	Virtualization 1	Read /write	1	UIntegerT(8)	<i>Animation</i>	
			2	UIntegerT(8)	<i>Color</i>	
			3	UIntegerT(8)	<i>Speed</i>	
0x82	Virtualization Virtualization 2	Read /write	1	UIntegerT(8)	<i>Animation</i>	
			2	UIntegerT(8)	<i>Color</i>	
			3	UIntegerT(8)	<i>Speed</i>	
0x83	Virtualization 3	Read /write	1	UIntegerT(8)	<i>Animation</i>	
			2	UIntegerT(8)	<i>Color</i>	
			3	UIntegerT(8)	<i>Speed</i>	
0x84	Virtualization 4	Read /write	1	UIntegerT(8)	<i>Animation</i>	
			2	UIntegerT(8)	<i>Color</i>	
			3	UIntegerT(8)	<i>Speed</i>	
0x85	Virtualization 5	Read /write	1	UIntegerT(8)	<i>Animation</i>	
			2	UIntegerT(8)	<i>Color</i>	
			3	UIntegerT(8)	<i>Speed</i>	
0x86	Virtualization 6	Read /write	1	UIntegerT(8)	<i>Animation</i>	
			2	UIntegerT(8)	<i>Color</i>	
			3	UIntegerT(8)	<i>Speed</i>	

Index	Funktion	Zugriff	Subindex	Datentyp	Beschreibung	Werkseinstellung
0x86	Virtualization 7	Read /write	1	UIntegerT(8)	<i>Animation</i>	
			2	UIntegerT(8)	<i>Color</i>	
			3	UIntegerT(8)	<i>Speed</i>	
0x90	Virtual position switch 0	Read /write	1	IntegerT(16)	<i>Switch position in 1/100 mm</i>	0
			2	UIntegerT(16)	<i>Switch position in 1/100 mm</i>	200
0x91	Virtual position switch 1	Read /write	1	IntegerT(16)	<i>Switch position in 1/100 mm</i>	0
			2	UIntegerT(16)	<i>Switch position in 1/100 mm</i>	200
0x92	Virtual position switch 2	Read /write	1	IntegerT(16)	<i>Switch position in 1/100 mm</i>	0
			2	UIntegerT(16)	<i>Switch position in 1/100 mm</i>	200
0x93	Virtual position switch 3	Read /write	1	IntegerT(16)	<i>Switch position in 1/100 mm</i>	0
			2	UIntegerT(16)	<i>Switch position in 1/100 mm</i>	200
0xA0	Diagnosis	Read Only	1	UIntegerT(16)	<i>Duration of the last successful gripping operation in milliseconds</i>	-
			2	UIntegerT(16)	<i>Duration of the last successful gripping operation in milliseconds</i>	-
			3	IntegerT(16)	<i>Current module temperature in 1/10 °C</i>	-
			4	UIntegerT(32)	<i>Gripping cycle count</i>	-
			5	IntegerT(32)	<i>Cycles remaining until next maintenance</i>	-
0x100	Protocol Entry 0	Read Only	1	UIntegerT(32)	<i>Time stamp measured in seconds since activation</i>	0
			2	StringT(140)	<i>Message text (max. 140 characters)</i>	"(not set)"
...						
0x109	Protocol Entry 9	Read Only	1	UIntegerT(32)	<i>Time stamp measured in seconds since activation</i>	0
			2	StringT(140)	<i>Message text (max. 140 characters)</i>	"(not set)"

Index	Funktion	Zugriff	Subindex	Datentyp	Beschreibung	Werkseinstellung
0x0140	Maintenance Interval	Read /write	0	UIntegerT(32)	<i>Number of gripping cycles after which maintenance is signaled</i>	2.000.000

Table 19: Device-specific process parameters

13 APPENDIX B - Configuration Example

Below the configuration of Integration Line gripping modules via IO-Link with a suitable IO-Link master at a PLC is described.

Control Elements Used

- SPS SIEMENS Simatic S7-1200 1212C DC/DC/Rly version 4, article number 6ES7 212-1HE40-0XB0
- IO-Link master SIEMENS SM 1278, article number 6ES7 278-4BD32-0XB0
- Configuration software SIEMENS TIA-Portal / STEP 7 Basic V13 SP1
- Port configurator SIEMENS S7-PCT 3.3 HF2

Prerequisites

The prerequisite for this example is that the PLC has been commissioned and configured in such a way that it can be accessed via the TIA portal. The configuration software and the port configurator must be installed. The operator should know the basic functionality of the TIA portal. Furthermore, it is assumed that the gripping module is properly wired to the IO-Link master. You can find information on the pin assignment in chapter 5.2.1.

13.1 Preparation

Create a new project in the TIA portal and configure the PLC. Set the IP address of the PLC in such a way that you can access the PLC via PROFINET. Then configure the IO-Link master SM 1278 (cf. Figure22).



The IO-Link master maps the cyclic process data of the gripping module into the I/O address space of the PLC. The address range is automatically assigned during project engineering and is stored in the device configuration.

13.2 Configuration of the IO-Link Master

You can start the S7-PCT port configurator by right-clicking on the respective IO-Link master (Figure 23). You must first import the IO-Link Device Description (IODD) file of the gripping module in S7-PCT (menu item “Extras” -> “Import IODD”). The gripping module then appears in the device catalog on the right. Per “drag & drop”, the suitable gripping module can then be dragged from the catalog to the IO-Link port of the master that you want to use (Figure 24).

By clicking on “Load” in the tool bar of S7-PCT, the port configuration is transferred to the IO-Link master. The IO-Link master now establishes a connection with the gripping module. The respective LEDs at the IO-Link master change to green.

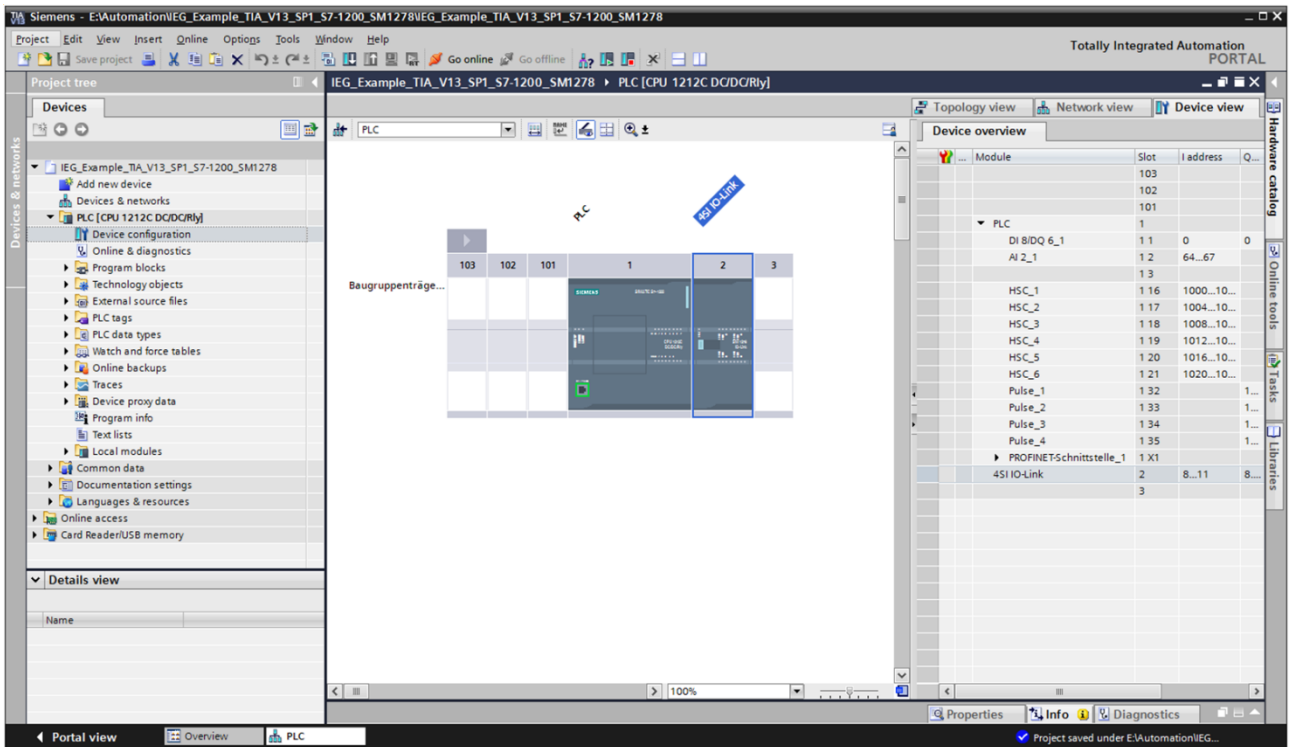

Figure 22: Configuration of the IO-Link master

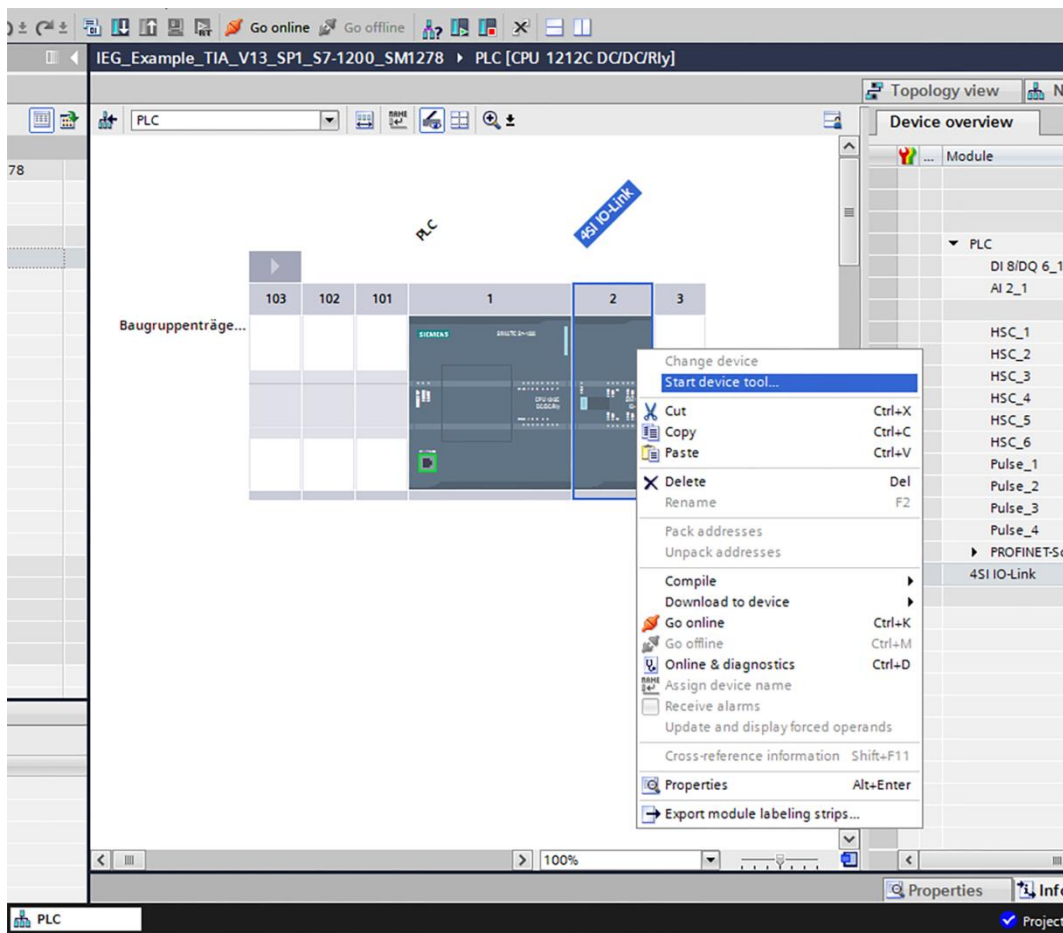

Figure 23: Starting the S7-PCT port configurator (device tool)

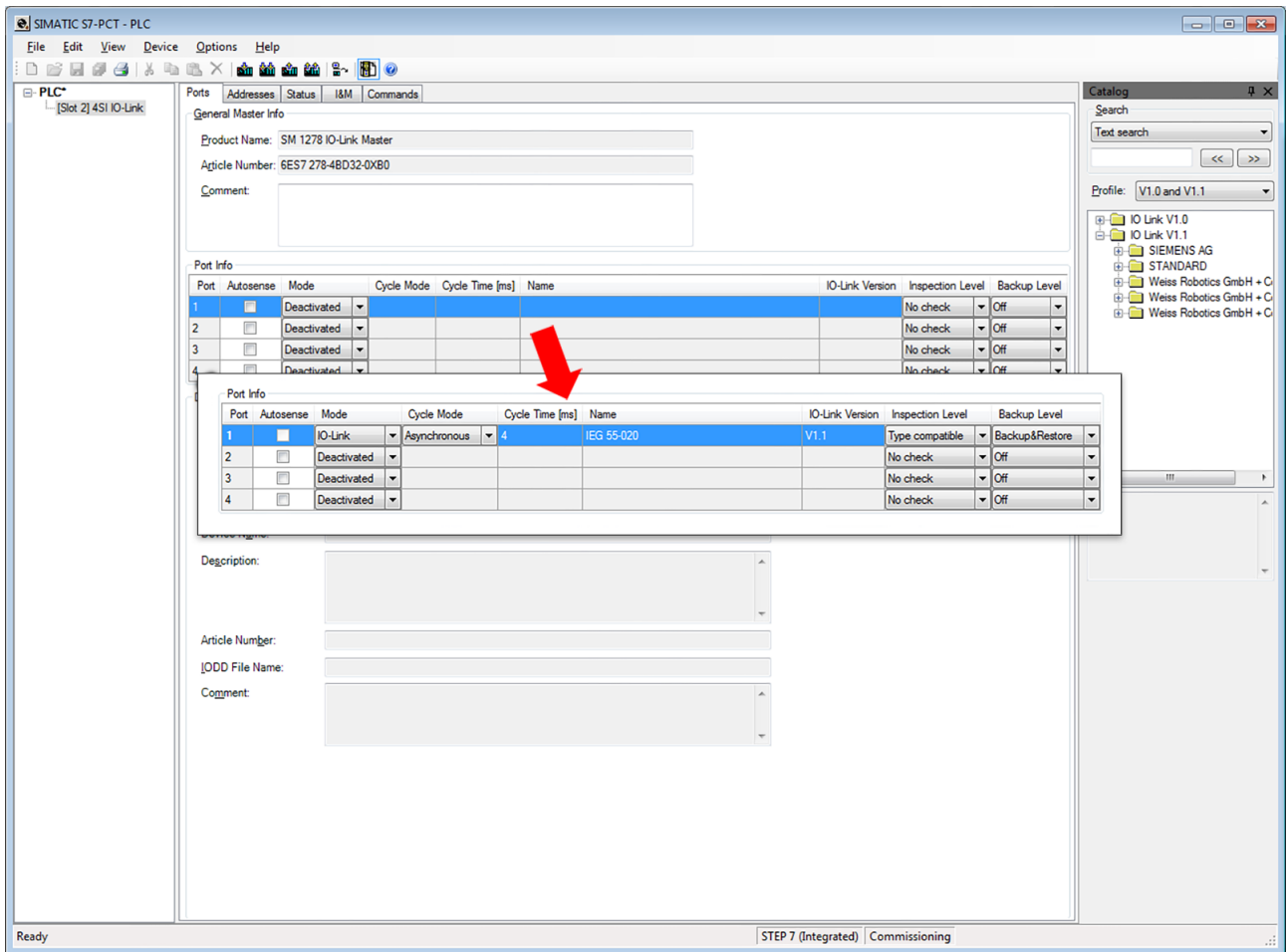

Figure 24: Configuration of the IO-Link port

13.3 Configuration of the Gripping Module

The gripping module can now be parameterized via the S7-PCT port configurator. By clicking on “Online” (IO-Link port selected in the selection tree on the left), the port configurator establishes a connection to the IO-Link master. By selecting the gripping module in the selection tree on the left, the parameterization of the gripping module is loaded. The tabs “Identification”, “Parameter”, and “Diagnosis” appear.

The “Identification” tab (Figure 25) shows the manufacturer, the type description, the firmware version, etc. of the gripping module. This information can be read only.

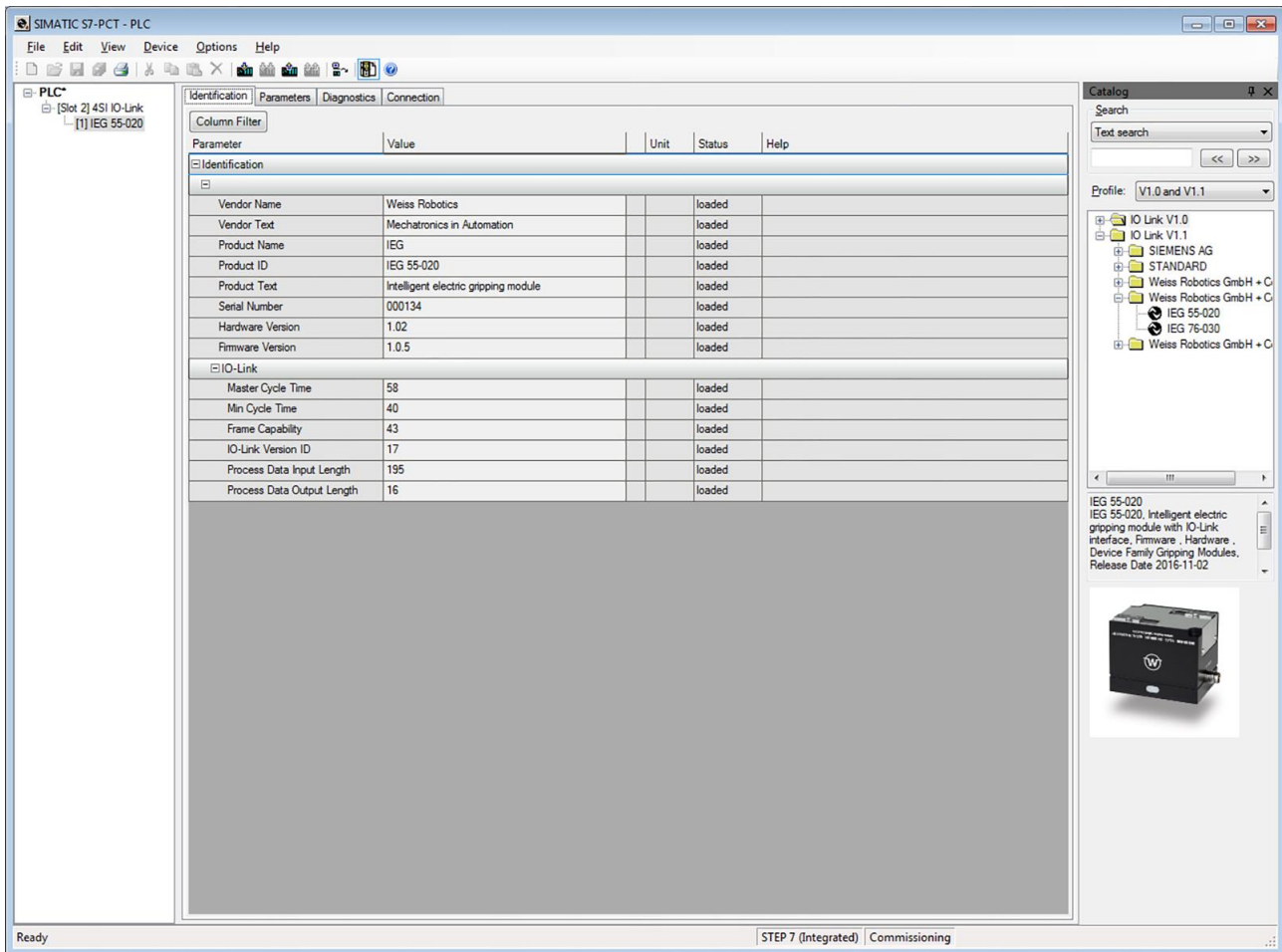

Figure 25: Identification of the gripping module in S7-PCT

13.4 Parameterization of the Gripping Module

The “Parameter” tab (Figure 26) shows the gripping parameters of the grip as well as the settings of the four virtual position switches. These values can be adjusted to your individual application.

The system commands can be issued via buttons, e.g. acknowledging that maintenance has been performed or permanently storing the configuration data in the gripping module.

The screenshot shows the SIMATIC Manager interface for parameterizing a gripping module. The main window is titled 'SIMATIC S7-PCT - PLC' and has tabs for 'Identification', 'Parameters', 'Diagnostics', and 'Connection'. The 'Parameters' tab is active, displaying a table of parameters. The table has columns for 'Parameter', 'Value', 'Unit', 'Status', and 'Help'. The parameters are organized into several sections:

- Device Access Locks:** Includes buttons for 'Device Reset', 'Restore Factory Setting', 'Confirm Maintenance', and 'Store Configuration permanently'.
- Motion:** Includes 'Motion Settings - Override Grip' (100.0, %), 'Motion Settings - Override Release Limit' (100.0, %), and 'Motion Settings - Invert homing' (0, %).
- Grip Presets:** Divided into four groups (Grip Preset 0 to 3). Each group has three parameters: 'No Part Limit' (0.5, mm), 'Release Limit' (19.5, mm), and 'Gripping Force' (100.0, %).
- Position Switches:** Divided into four groups (Position Switch 0 to 3). Each group has two parameters: 'Switch Position' (0.0, mm) and 'Switch Width' (2.0, mm).
- Extended Configuration:** Includes 'Maintenance Interval' (2000000, loaded).

The status bar at the bottom of the window shows 'Ready' on the left and 'STEP 7 (Integrated) Commissioning' on the right.

Figure 26: Parameters of the gripping module in S7-PCT

13.5 Diagnosis

The “Diagnosis” tab (Figure 27) shows various diagnosis data as well as the event log memory of the gripping module. This information can be read only. The “Diagnosis” tab provides information on the current state of the gripping module. Logged events can also be displayed.

The screenshot displays the SIMATIC Manager interface for an S7-PCT PLC. The 'Diagnostics' tab is active, showing a table of diagnostic parameters and a system log. The status bar at the bottom indicates 'STEP 7 (Integrated) Commissioning'.

Parameter	Value	Unit	Status	Help
Diagnostics				
Error Count	0		loaded	
Device Status	Device is OK		loaded	
Diagnostics - Grp Time for last grp	0.0	ms	loaded	
Diagnostics - Release Time for la...	0.0	ms	loaded	
Diagnostics - Temperature	24.2	°C	loaded	
Diagnostics - Number of Grip Cyc...	0		loaded	
Diagnostics - Grip Cycles left until...	10000000		loaded	
System Log				
Entry 0				
Entry 0 - Timestamp	0		loaded	
Entry 0 - Message	(not set)		loaded	
Entry 1				
Entry 1 - Timestamp	0		loaded	
Entry 1 - Message	(not set)		loaded	
Entry 2				
Entry 2 - Timestamp	0		loaded	
Entry 2 - Message	(not set)		loaded	
Entry 3				
Entry 3 - Timestamp	0		loaded	
Entry 3 - Message	(not set)		loaded	
Entry 4				
Entry 4 - Timestamp	0		loaded	
Entry 4 - Message	(not set)		loaded	
Entry 5				
Entry 5 - Timestamp	0		loaded	
Entry 5 - Message	(not set)		loaded	
Entry 6				
Entry 6 - Timestamp	0		loaded	
Entry 6 - Message	(not set)		loaded	
Entry 7				
Entry 7 - Timestamp	0		loaded	
Entry 7 - Message	(not set)		loaded	
Entry 8				
Entry 8 - Timestamp	0		loaded	
Entry 8 - Message	(not set)		loaded	

Figure 27: Diagnostics data of the gripping module in S7-PCT

14 EC Declaration of Incorporation

According to EC Machinery Directive 2006/42/EG, appendix II B

Manufacturer Weiss Robotics GmbH & Co. KG
 Karl-Heinrich-Käferle-Str. 8
 D-71640 Ludwigsburg

Distributor Weiss Robotics GmbH & Co. KG
 Karl-Heinrich-Käferle-Str. 8
 D-71640 Ludwigsburg

We hereby declare that the following product:

Product designation: Servo-electrical gripping module
Type: CRG
Part numbers 5010016 (CRG 30-050), 5010017 (CRG 200-085)

meets the applicable basic requirements of the **Machinery Directive (2006/42/EC)**.

The incomplete machine may not be put into operation until it is confirmed that the machine into which the incomplete machine is to be installed meets the provisions of the Machinery Directive (2006/42/EC).

Applied harmonized standards, especially:

EN ISO 12100-1 Safety of machines – Basic concepts, general principles for design – Part 1:
 Basic terminology, methodology

EN ISO 12100-2 Safety of machines – Basic concepts, general principles for design – Part 2:
 Technical principles

The manufacturer agrees to forward the special technical documents for the incomplete machine to state offices on demand. The special technical documents according to Annex VII, Part B, belonging to the incomplete machine have been created.

Person responsible for documentation: Dr.-Ing. Karsten Weiß, Tel.: +49(0)7141/94702-0

Location, Date/Signature: Ludwigsburg, February 1, 2018

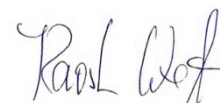

Details of the signatory: Weiss Robotics GmbH & Co. KG



www.weiss-robotics.com

© Weiss Robotics GmbH & Co. KG. All rights reserved.

The technical data mentioned in this document can be changed to improve our products without prior notice. Used trademarks are the property of their respective trademark owners. Our products are not intended for use in life support systems or systems whose failure can lead to personal injury.